

Invariant Subspaces of Nilpotent Linear Operators. I.

Claus Michael Ringel and Markus Schmidmeier

Abstract. Let k be a field. We consider triples (V, U, T) , where V is a finite dimensional k -space, U a subspace of V and $T: V \rightarrow V$ a linear operator with $T^n = 0$ for some n , and such that $T(U) \subseteq U$. Thus, T is a nilpotent operator on V , and U is an invariant subspace with respect to T . We will discuss the question whether it is possible to classify these triples. These triples (V, U, T) are the objects of a category with the Krull-Remak-Schmidt property, thus it will be sufficient to deal with indecomposable triples. Obviously, the classification problem depends on n , and it will turn out that the decisive case is $n = 6$. For $n < 6$, there are only finitely many isomorphism classes of indecomposable triples, whereas for $n > 6$ we deal with what is called “wild” representation type, so no complete classification can be expected. For $n = 6$, we will exhibit a complete description of all the indecomposable triples.

Let k be a field which will be fixed throughout the paper (of interest should be $k = \mathbb{C}$ or $k = \mathbb{R}$, but also the cases where k is finite). We consider a finite-dimensional k -space V with a linear operator $T: V \rightarrow V$ which is nilpotent, say satisfying $T^n = 0$ for some natural number n , and we are interested in the subspaces U of V which are T -invariant (this means that $T(U) \subseteq U$). To be more precise, we fix the number n , look for all such triples $X = (V, U, T)$ and ask for a classification of the isomorphism classes: We consider these triples (V, U, T) as the objects of a category $\mathcal{S}(n)$ (or $\mathcal{S}_k(n)$ in case a reference to the base field k is needed); for two such triples (V, U, T) and (V', U', T') , a map $(V, U, T) \rightarrow (V', U', T')$ is given by a k -linear map $f: V \rightarrow V'$ with $f(U) \subseteq U'$ and such that $fT = T'f$. Note that a map $f: (V, U, T) \rightarrow (V', U', T')$ in $\mathcal{S}(n)$ is an isomorphism provided f is bijective and $f(U) = U'$. The category $\mathcal{S}(n)$ is additive, the *direct sum* of two objects $X = (V, U, T)$ and $X' = (V', U', T')$ is the triple $X \oplus X' = (V \oplus V', U \oplus U', T \oplus T')$; the *zero object* is $(0, 0, 0)$. The triple (V, U, T) is said

2000 *Mathematics Subject Classification.* Primary: 47A15, 15A21. Secondary: 15A04, 16D70, 16G30, 16G60, 18G25, 47C99.

Keywords: Nilpotent operators. Invariant subspaces. Auslander-Reiten quivers. Tubular categories. Coverings.

to be *indecomposable* provided it is not zero and not isomorphic to a direct sum $X \oplus X'$ with non-zero objects X, X' . The aim of this paper is a study of the categories $\mathcal{S}(n)$, in particular we ask for a classification of the indecomposable objects.

(0.1) Crucial results. The difficulty of classifying the indecomposable objects in $\mathcal{S}(n)$ increases with increasing n . Whereas for $n \leq 5$ there are only finitely many isomorphism classes of indecomposable triples, there are infinitely many such classes for $n \geq 6$. Our main concern will be the case $n = 6$ which turns out to be a “tame” case: here, a complete classification is possible, as we will show in Part A of the paper. Part B will provide some information on the “finite type” cases $n < 6$ as well as on the “wild” cases $n > 6$.

The description of the category $\mathcal{S}_k(6)$ presented in this paper may look complicated, but it allows to draw a lot of interesting consequences. Some of these consequences can be formulated and understood very easily, this we are going to do now — but at the moment, no elementary proofs seem to be available. Let us introduce an obvious invariant, namely the *dimension pair* $(\dim V, \dim U)$ of a triple (V, U, T) in $\mathcal{S}(n)$; it is a pair (v, u) of natural numbers with $u \leq v$.

(0.1.1) *A pair (v, u) of natural numbers with $u \leq v$ is the dimension pair of an indecomposable object in $\mathcal{S}(6)$ if and only if the following two conditions are satisfied: first,*

$$|v - 2u| \leq 6,$$

and second, (v, u) is different from $(0, 0), (7, 1), (8, 1), (7, 6), (8, 7)$.

This means that the dimension pairs (v, u) of the indecomposable triples (V, U, T) in $\mathcal{S}(6)$ lie in the following shaded region (the exceptions are encircled):

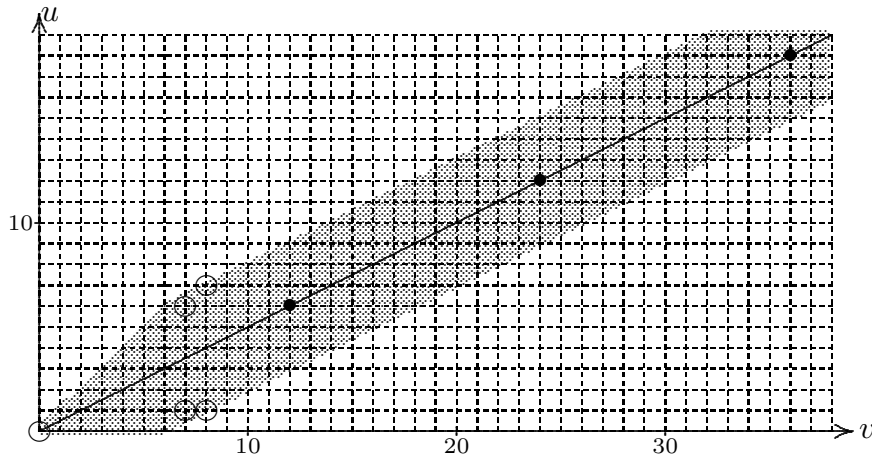

One observes that for an indecomposable triple (V, U, T) in $\mathcal{S}(6)$, the dimension of the subspace U is roughly half of the dimension of the total space V . Let us stress the symmetry with respect to the operation $\delta: (v, u) \mapsto (v, v - u)$ (it fixes the points on the line through $(2, 1)$ and maps a point with vertical distance

$\frac{1}{2}v - u$ below the line to the corresponding point of the same vertical distance above the line). This operation describes duality: The categories $\mathcal{S}(n)$ have the self duality $*$ = $\text{Hom}_k(-, k)$ which maps an object (V, U, T) with dimension pair (v, u) to the object $(V, U, T)^* = (V^*, (V/U)^*, T^*)$ with dimension pair $\delta(v, u)$.

Actually, for $n \leq 6$ we even have $|v - 2u| \leq n$, whereas for $n \geq 7$, the numbers $|v - 2u|$ are not bounded. The black dots in the picture indicate the positions which are positive integral multiples of $(12, 6)$; the difference between these dimension pairs and the remaining ones will be discussed next.

(0.1.2) *Assume that (v, u) is not an integral multiple of $(12, 6)$. Then the number of isomorphism classes of indecomposable objects in $\mathcal{S}_k(6)$ with dimension pair (v, u) is finite and is independent of k .*

By contrast, the indecomposable objects in $\mathcal{S}_k(6)$ with dimension pair an integral multiple of $(12, 6)$ will depend on the field k .

(0.1.3) *Let k be an infinite field. Let v, u be natural numbers. Then: There are infinitely many isomorphism classes of indecomposable objects in $\mathcal{S}_k(6)$ with dimension pair (v, u) if and only if (v, u) is a positive integral multiple of $(12, 6)$.*

It may be worthwhile to exhibit here a family of indecomposable triples $X_c = (V, U_c, T)$ with dimension pair $(12, 6)$. Let V be a k -space with basis e_1, \dots, e_{12} , let T be defined by $T(e_i) = 0$ for $i \in \{1, 7, 11\}$ and $T(e_i) = e_{i-1}$ otherwise (thus T is given by the partition $(6, 4, 2)$). Let U_c be the subspace generated by $e_3 + e_8$, $e_{11} - e_8$ and $ce_4 + (c - 1)e_9 + e_{12}$, with $c \in k$. All these triples X_c are indecomposable and they are pairwise non-isomorphic; we obtain in this way a *one-parameter family indexed by k* . If we consider indecomposable triples (V, U, T) with dimension pair $(24, 12)$, then there are already two disjoint one-parameter families, both being indexed by k ; for one family, the space V is given by the partition $(6, 6, 4, 4, 2, 2)$, for the second family, by $(6, 6, 5, 3, 3, 1)$. In case k is algebraically closed, there is the following general result:

(0.1.4) *Let k be an algebraically closed field, let $t \in \mathbb{N}_1$. Then there are t pairwise disjoint one-parameter families of indecomposable objects in $\mathcal{S}_k(6)$ with dimension pair $(12t, 6t)$, each one being indexed by k , and such that there are only a finite number of additional isomorphism classes of indecomposable triples with dimension pair $(12t, 6t)$.*

Assertions (0.1.3) and (0.1.4) show that the classification of the indecomposable objects in $\mathcal{S}(6)$ is what is called a tame, but non-domestic problem with linear growth (of the number of one-parameter families). An index set for the indecomposable triples in $\mathcal{S}(6)$ will be provided in this paper. For a detailed description and further properties of these indecomposable triples, we refer to the forthcoming Part II [12] (in particular, there we will see that for almost all indecomposable triples (V, U, T) with dimension pair $(12t, 6t)$, the dimension of the kernel of T is $3t$, whereas the dimensions of the kernels of the endomorphisms induced by T on U as well as on V/U both are $2t$).

We now draw the attention to the endomorphism rings $\text{End}(X)$ of indecomposable objects X in $\mathcal{S}(6)$. These endomorphism rings are usually rather large, however the bulk of endomorphisms will be nilpotent with nilpotency index at most 8.

(0.1.5) *Let X be an indecomposable object in $\mathcal{S}_k(6)$ with dimension pair (v, u) . Then there is an ideal I in $\text{End}(X)$ with $I^8 = 0$ such that $\text{End}(X)/I$ is a local uniserial ring.*

The ideal I can be described using the notion of the infinite radical of a category. Given a Krull-Remak-Schmidt category such that the indecomposable objects have local endomorphism rings (such as $\mathcal{S}(n)$), its *radical* \mathcal{R} is by definition the class of all maps $g: X \rightarrow Y$ such that for any pair of maps $f: X' \rightarrow X$ and $h: Y \rightarrow Y'$ with X' and Y' indecomposable, the composition hgf is a non-isomorphism. Then \mathcal{R} forms a categorical ideal. We are interested in the *infinite radical*, $\mathcal{I} = \bigcap_{i \in \mathbb{N}} \mathcal{R}^i$.

(0.1.6) *In the category $\mathcal{S}(6)$, the infinite radical \mathcal{I} is an idempotent ideal, that is, $\mathcal{I}^2 = \mathcal{I}$ holds. If X is an indecomposable object in $\mathcal{S}(6)$, then the ideal $\mathcal{I}(X, X)$ of $\text{End}(X)$ has nilpotency index at most 8.*

The ideal I to be used in Assertion (0.1.5) is $I = \mathcal{I}(X, X)$.

An inclusion map $(V', U', T') \rightarrow (V, U, T)$ is called an *inflation* provided $U' = U \cap V'$, thus provided the induced map $U/U' \rightarrow V/V'$ is injective. If $X' = (V', U', T') \rightarrow (V, U, T) = X$ is an inflation, then we can form X/X' with total space V/V' , subspace U/U' and with the linear operator on V/V' induced by T . Let X be an indecomposable object. Call X *m-stackable* provided there is an indecomposable object Y with a chain of inflations

$$0 = Y_0 \rightarrow Y_1 \rightarrow \cdots \rightarrow Y_m = Y$$

such that all the objects Y_i/Y_{i-1} with $1 \leq i \leq m$ are isomorphic to X .

(0.1.7) *Assume that X is an indecomposable object in $\mathcal{S}(6)$ with dimension pair (v, u) . If (v, u) is an integral multiple of $(12, 6)$, then X is m -stackable for every $m \in \mathbb{N}_1$. If (v, u) is not a multiple of $(2, 1)$, and X is m -stackable for some $m \in \mathbb{N}_1$, then $m \leq 6$.*

Here, we provide no assertion concerning the cases where (v, u) is a multiple of $(2, 1)$, but not an integral multiple of $(12, 6)$. It seems to us that in these cases X can be m -stackable only for $m \leq 5$. Note that in the categories $\mathcal{S}(n)$ with $n \leq 5$, all the indecomposable objects can be m -stackable only for $m \leq n$, and those with dimension pair a multiple of $(2, 1)$ can be m -stackable only for $m \leq n - 1$.

(0.2) A general frame. We may reformulate (and generalize) the problem to be considered as follows: If Λ is any ring, let $\mathcal{S}(\Lambda)$ be the category of pairs (A, A') ,

where A is a finitely generated Λ -module and $A' \subseteq A$ is a submodule of A ; a map $f: (A, A') \rightarrow (B, B')$ in $\mathcal{S}(\Lambda)$ is just a Λ -linear map $f: A \rightarrow B$ such that $f(A') \subseteq B'$ holds. We may call $\mathcal{S}(\Lambda)$ the *submodule category* of Λ -modules. One will observe that

$$\mathcal{S}_k(n) = \mathcal{S}(k[x]/x^n)$$

where $k[x]$ is the polynomial ring with variable x ; namely, a pair (V, T) consisting of a k -vector space and a linear operator $T: V \rightarrow V$ with $T^n = 0$ is in an obvious way a $k[x]/x^n$ -module, and a subspace U of V with $T(U) \subseteq U$ leads to a pair $(U, T|_U)$ which is just a submodule of (V, T) . Note that the ring $k[x]/x^n$ is a commutative uniserial ring of length n and one may wonder about the similarities of the various categories $\mathcal{S}(\Lambda)$, with Λ a commutative uniserial ring of length n . In fact, our interest in the problem discussed in this paper arose from the Birkhoff problem [2] of classifying subgroups of finite abelian p -groups. The Birkhoff problem concerns the categories $\mathcal{S}(\mathbb{Z}/p^n)$, thus also here we deal with a commutative uniserial ring of length n , namely \mathbb{Z}/p^n . The combinatorial structure for the categories $\mathcal{S}(n)$ with $n \leq 5$ presented in Section 6 is the same as for $\mathcal{S}(\mathbb{Z}/p^n)$. The structure of the category $\mathcal{S}(\mathbb{Z}/p^6)$ is not yet known — it is a challenging question whether it looks like the category $\mathcal{S}_k(6)$, for $k = \mathbb{Z}/p$, exhibited in this paper.

Assume now that Λ is an artinian ring (for example a finite-dimensional k -algebra, as is the case when $\Lambda = k[x]/x^n$). We may consider $\mathcal{S}(\Lambda)$ as the full subcategory of the category $\mathcal{H}(\Lambda)$ of finitely generated modules over the ring $\begin{bmatrix} \Lambda & \Lambda \\ 0 & \Lambda \end{bmatrix}$ of upper triangular matrices as follows: Write the pair (A, A') in $\mathcal{S}(\Lambda)$ as column vectors $\begin{bmatrix} A \\ A' \end{bmatrix}$ and just use matrix multiplication. In this way, one sees immediately that $\mathcal{S}(\Lambda)$ inherits the Krull-Remak-Schmidt property from $\mathcal{H}(\Lambda)$: Any object in $\mathcal{S}(\Lambda)$ is the direct sum of a finite number of indecomposable objects and these indecomposable direct summands are unique up to isomorphism. Thus, in order to classify all the isomorphism classes of triples (V, U, T) in $\mathcal{S}(\Lambda)$, it is sufficient to consider the indecomposable ones. We return now to the case $\Lambda = k[x]/x^n$.

(0.3) Auslander-Reiten theory. The description of the categories $\mathcal{S}(n)$ presented in this paper uses notions and results from the modern representation theory of finite dimensional k -algebras, see for example [1] and [9]. The basic notions of Auslander-Reiten theory lead to the possibility of presenting suitable additive categories such as $\mathcal{S}(n)$ at least partly by a translation quiver, and the components of this Auslander-Reiten quiver of $\mathcal{S}(n)$ will be of our concern.

For each $n < 6$ we will present the Auslander-Reiten quiver of $\mathcal{S}(n)$ in Section 6. For $n > 6$, we can refer to [10] where it is shown that the category $\mathcal{S}_k(n)$ is controlled k -wild; in this case the problem of classifying all objects is considered infeasible. Still we can present some features of these categories in Section 7. But as we have mentioned already, the most interesting case seems to be the borderline case $n = 6$; Part A (as well as the forthcoming paper [12]) is devoted to exhibit its structure.

The determination of the structure of the Auslander-Reiten components of $\mathcal{S}_k(6)$ relies on methods from the representation theory of quivers which are by now standard: the knitting of preprojective components, the covering theory of the Gabriel school, as well as the use of one-point extensions, in particular the tubular extension techniques as outlined in [9]. However, all these methods have to be modified since we do not deal with a module category, but only with an exact category. The necessary modification of these standard tools will be outlined below. It is amazing that the results obtained are close to corresponding results concerning module categories. In particular, the structure of the category $\mathcal{S}(6)$ turns out to be very similar to the structure of some module categories.

In order to describe the structure of the category $\mathcal{S}_k(6)$, one needs the notion of a tube, or better of tubular families. Tubular families are sets of Auslander-Reiten components all of which are tubes and being indexed by the projective line $\mathbb{P}_1(k)$ (in case k is algebraically closed, $\mathbb{P}_1(k)$ may be considered as the disjoint union of k itself and an additional symbol ∞ ; in general, $\mathbb{P}_1(k)$ is the disjoint union of the set of monic irreducible polynomials over k and the additional symbol ∞). Let us try to give at least an intuitive picture of the global structure of the category $\mathcal{S}_k(6)$, it turns out to be a category of tubular type (E_8) . Each indecomposable object, up to isomorphism, is uniquely determined by three parameters

- the first one is a non-negative rational number $\gamma \in \mathbb{Q}_0^+$,
- the second is an element $c \in \mathbb{P}_1(k)$,
- and as third parameter one can take a natural number $m \in \mathbb{N}$.

Conversely, any combination (γ, c, m) occurs in this way, thus we obtain in this way a complete set of invariants.

If we fix the first index γ , then we obtain the tubular family $\bar{\mathcal{T}}_\gamma$ by taking all the indecomposable triples with first index γ . Instead of taking the set \mathbb{Q}_0^+ as first index set, we should better consider the topological space $\{e^{2\pi i \frac{p}{p+q}} \mid \gamma = \frac{p}{q} \in \mathbb{Q}_0^+\}$, so that the points corresponding to 0 and ∞ in $\mathbb{Q}_0^+ \cup \{\infty\}$ get identified:

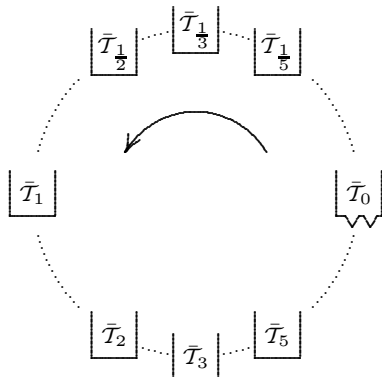

As we have mentioned, for each value of γ , there is a tubular family $\bar{\mathcal{T}}_\gamma$, thus a collection of Auslander-Reiten components which are tubes and which are parametrized by the second parameter c from $\mathbb{P}_1(k)$. All the tubes in $\bar{\mathcal{T}}_\gamma$ but three are

homogeneous ones, the exceptional ones (say with second parameter $c = 1, 0, \infty$) are tubes of rank 2, 3, and 6, respectively. The third parameter m enumerates the triples in a given tube: there are countable many isomorphism classes of triples which belong to any tube. For the homogeneous tubes, there is indeed a natural bijection with the set of natural numbers, but for the exceptional tubes the use of natural numbers as the third parameter may be considered as rather misleading, it should be considered only as a first attempt to get an impression of the diversity of the isomorphism classes in $\mathcal{S}(6)$. As the proper third index set one should replace \mathbb{N} by the vertices of a tube of rank $r(c)$, depending on the second parameter c , with $r(\infty) = 6$, $r(0) = 3$, $r(1) = 2$, and $r(c) = 1$ otherwise.

One deviation has to be mentioned: All but one of the tubular families $\bar{\mathcal{T}}_\gamma$ have the same shape, the only exception occurs for $\gamma = 0$. Here, the tube of rank 6 is not stable but contains two projective-injective vertices; this should explain the curious shape used in the picture above. The three non-homogeneous tubes in the tubular family $\bar{\mathcal{T}}_0$ (which we also denote by $\bar{\mathcal{U}}$) will be exhibited in detail in Section 2.

We have mentioned already that the distribution of the indecomposable triples of $\mathcal{S}_k(6)$ into tubes yields the Auslander-Reiten components of the category $\mathcal{S}_k(6)$, thus we describe in this way the factor of this category modulo the infinite radical. But this concerns only the third parameter, whereas the first two parameters yield information on the infinite radical. The arrangement of the tubular families along a circle indicates that the homomorphisms in the infinite radical go counterclockwise (see Theorem (1.5.2) and Lemma (2.2.2) for details). The picture presented above includes a corresponding arrow in order to stress the global direction of homomorphisms in the infinite radical. In particular, the endomorphism of an object (V, U, T) given by multiplication by T always belongs to the infinite radical.

(0.4) Covering theory. In order to visualize indecomposable objects in $\mathcal{S}(n)$, we will use two different ways, namely pairs of sequences of natural numbers, as well as box diagrams (see for example Section 2). Both ways rely on the use of covering theory which we now want to explain, since it is the essential tool for our investigation.

As we have seen, the objects of the category $\mathcal{S}(n)$ can be described as triples (V, U, T) or also as pairs of a $k[x]/x^n$ -module and a submodule. But there is a third description for these objects, namely as representations of the quiver

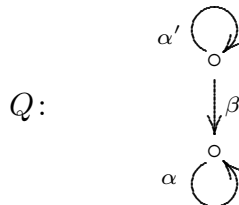

which satisfy the relations $\beta\alpha' = \alpha\beta$ and $\alpha^n = 0$, and with the additional requirement that the map β is an inclusion map. (We do not have to mention the condition $(\alpha')^n = 0$ since it follows from the two relations $\beta\alpha' = \alpha\beta$ and $\alpha^n = 0$ in case β is assumed to be injective). We also will consider the following (infinite) quiver (with respect to the given relations, this is what is called the universal covering for Q):

$$\tilde{Q}: \begin{array}{ccccccccccc} \dots & \xleftarrow{\alpha'_0} & \circ & \xleftarrow{\alpha'_1} & \circ & \xleftarrow{\alpha'_2} & \circ & \xleftarrow{\alpha'_3} & \dots & & \\ & & \downarrow \beta_0 & & \downarrow \beta_1 & & \downarrow \beta_2 & & & & \\ \dots & \xleftarrow{\alpha_0} & \circ & \xleftarrow{\alpha_1} & \circ & \xleftarrow{\alpha_2} & \circ & \xleftarrow{\alpha_3} & \dots & & \end{array}$$

Usually, we will refrain from mentioning the indices of the arrows $\alpha_i, \alpha'_i, \beta_i$ and just write α, α', β . The representations of $k\tilde{Q}$ which satisfy the commutativity relations $\beta\alpha' = \alpha\beta$ (for all squares), the nilpotency relations $(\alpha')^n = \alpha^n = 0$ (for all compositions of n arrows α' or α) and for which all the maps β are realized by monomorphisms form the objects of a category which we will denote by $\mathcal{S}(\tilde{n})$, and which will play an important role throughout the paper.

Of course, we may interpret also $\mathcal{S}(\tilde{n})$ as a submodule category, namely for an infinite dimensional algebra which we denote by $kA_\infty^\infty/\alpha^n$,

$$\mathcal{S}(\tilde{n}) = \mathcal{S}(kA_\infty^\infty/\alpha^n).$$

Here, $kA_\infty^\infty/\alpha^n$ is the factor algebra of the path algebra kA_∞^∞ of the following infinite quiver

$$A_\infty^\infty: \quad \dots \quad \longleftarrow \circ \longleftarrow \circ \longleftarrow \circ \longleftarrow \dots$$

modulo the ideal generated by the relations $\alpha^n = 0$ (all arrows being labelled α).

The categories $\mathcal{S}(\tilde{n})$ and $\mathcal{S}(n)$ are related by an important functor

$$\mathcal{S}(\tilde{n}) \longrightarrow \mathcal{S}(n),$$

the so-called covering functor. This functor assigns to a representation (A, A') in $\mathcal{S}(\tilde{n})$ the triple (V, U, T) in $\mathcal{S}(n)$ using for V und U the direct sums $V = \bigoplus_{i \in \mathbb{Z}} A_i$ and $U = \bigoplus_{i \in \mathbb{Z}} A'_i$, respectively; note that the diagonal map $\bigoplus_{i \in \mathbb{Z}} \beta_i: \bigoplus_{i \in \mathbb{Z}} A'_i \rightarrow \bigoplus_{i \in \mathbb{Z}} A_i$ provides an embedding of U into V , and the linear operator T on V is given by the action of the maps corresponding to the arrows α .

We will see that for $n \leq 6$, the covering functor is dense, thus any indecomposable triple (V, U, T) in $\mathcal{S}(n)$ is obtained from a representation (A, A') of \tilde{Q} , and this representation (A, A') is unique up to the shift, thus its properties can be used in order to find invariants of (V, U, T) .

(0.5) Contents. The paper is organized as follows: As we have mentioned there are two parts. Part A with Sections 1, 2, 3 and 4 is devoted to the case $n =$

6, whereas the Sections 6 and 7 are devoted to the cases $n < 6$ and $n > 6$, respectively. Part B consists of these Sections 6, 7 and an additional Section 5 which provides information concerning some boundary objects in general.

In Section 1 we will see that $\mathcal{S}(\tilde{6})$ has tame representation type, more precisely, it is of tubular type (E_8) , and we exhibit the complete structure of its Auslander-Reiten quiver.

The topic of Section 2 is the covering functor $\mathcal{S}(\tilde{n}) \rightarrow \mathcal{S}(n)$. We will see that in case $n \leq 6$ the covering functor is dense, hence it induces a bijection between the \mathbb{Z} -orbits of indecomposable objects in $\mathcal{S}(\tilde{n})$ under the shift $M \mapsto M[1]$, and the indecomposable objects in $\mathcal{S}(n)$. In particular, we can use results from Section 1 in order to obtain not only a full list of the indecomposable objects in $\mathcal{S}(6)$, but also the Auslander-Reiten quiver for $\mathcal{S}(6)$.

In Section 3 we demonstrate the crucial results stated in (0.1).

Section 4 provides a slightly different approach for the study of $\mathcal{S}(n)$. A modification of an essential part of the quiver \tilde{Q} leads us to a finite dimensional algebra Ω which provides a sort of double covering of $\mathcal{S}(n)$. This approach has the advantage that we obtain in this way an abelian category, namely the category of Ω -modules, which is very similar to the category $\mathcal{S}(6)$.

In Part B we consider the category $\mathcal{S}(n)$ for arbitrary n . Topic of Section 5 are the objects which form the boundary of the non-stable component of the Auslander-Reiten quiver of $\mathcal{S}(n)$ (including the projective-injective ones). They are of similar nature for all the categories $\mathcal{S}(n)$.

In Section 6 we assume that $n < 6$; then $\mathcal{S}(n)$ has finite representation type. We specify the Auslander-Reiten quivers and picture each of the indecomposable objects. It turns out that the number $s(n)$ of indecomposables is given by the formula

$$s(n) = 2 + 2(n - 1) \frac{6}{6 - n}.$$

We motivate this formula and note that it still makes sense for $n = 6$ (with both sides being infinite). However for $n = 7$ the right side yields -70 , and we do not know any interpretation of this number in terms of representation theory.

In Section 7 we will consider the case where $n > 6$. Then each of the categories $\mathcal{S}(n)$ has wild representation type; at least we can determine the shape of the components of the Auslander-Reiten quiver: There is one tube containing the boundary objects on its mouth; all the other components are stable tubes of diameter a divisor of 6. Also each corresponding category $\mathcal{S}(\tilde{n})$ is wild; here the connected components of the Auslander-Reiten quiver have stable type $\mathbb{Z}A_\infty$. We can construct in $\mathcal{S}(\tilde{n})$ indecomposable representations of arbitrarily large support.

There is an Appendix which outlines in which way considerations concerning nilpotent operators are of interest when dealing with operators in general.

Notation. In this paper we will study representations of the quiver Q , as well as of various full subquivers Q' of the quiver \tilde{Q} (taking into account the given

relations). The projective, injective, and simple representations corresponding to a vertex z of a quiver will be denoted by $P(z)$, $I(z)$, and $S(z)$, respectively. For M a representation, M_z is the k -space at position z . For M a representation of \tilde{Q} and ℓ an integer, $M[\ell]$ is the representation of \tilde{Q} obtained by shifting M by ℓ steps in direction opposite to α . Thus, $M[\ell]_i = M_{i-\ell}$ and $M[\ell]_{i'} = M_{(i-\ell)'}$, for $i \in \mathbb{Z}$. If \mathcal{A} is a Krull-Remak-Schmidt category, we denote by $\text{ind } \mathcal{A}$ the class of indecomposable objects in \mathcal{A} (or the choice of one from each isomorphism class). For unexplained notions we refer to [9] and [1].

(0.6) History and related results. As we have mentioned, it was Birkhoff [2] who urged to study subcategories of the form $\mathcal{S}(\Lambda)$, at least for the rings $\Lambda = \mathbb{Z}/p^n$. The indecomposable objects in $\mathcal{S}(\mathbb{Z}/p^n)$ have been determined in [8] in the cases where $n \leq 5$. More generally, one may consider not only submodules, but even chains of submodules, as proposed by Simson in [14]. For each pair ℓ, n of natural numbers, he determined the representation type of the category of chains of length ℓ of submodules of $k[x]/x^n$ -modules (in particular, he already has shown that the category $\mathcal{S}(6)$ which we will study in detail, is tame).

Also, for $m \leq n$, let us denote by $\mathcal{S}(n; m)$ the full subcategory of $\mathcal{S}(n) = \mathcal{S}_k(n)$ of all triples (V, U, T) such that $T^m(U) = 0$. In [13] the representation type of $\mathcal{S}(n; m)$ has been determined for each pair (m, n) with $m < n$, and in each finite or tame case a description of the indecomposable modules has been given.

In a forthcoming paper [12] we are going to expand the study of the category $\mathcal{S}(6)$ considerably. We will outline the relevance of the tubular family $\tilde{\mathcal{T}}_1$ and we will show in which way the two half circles of tubular families $\{\tilde{\mathcal{T}}_\gamma \mid 0 < \gamma < 1\}$ and $\{\tilde{\mathcal{T}}_\gamma \mid 1 < \gamma < \infty\}$ are built up from the tubular families $\tilde{\mathcal{T}}_0$ and $\tilde{\mathcal{T}}_1$. Also, we will see that the objects in $\mathcal{S}(6)$ are strongly related to the representations of a partially ordered set with 9 vertices.

(0.7) Acknowledgement. Most of the results presented here have been obtained in the years 2000-2002. They have been reported in various lectures since that time, and many comments of the audience have helped us to improve the results. Unfortunately, it took a long time to complete a final version. The authors are grateful to the European Union for providing the possibility for the start of this cooperation (at a rather boring midterm review meeting in 2000 where the EU representatives insisted that the discussions should only concern administrative matters, and not mathematics ...).

Part A. Operators with Nilpotency Index 6

We give a description of all indecomposable triples (V, U, T) where the linear operator acts with nilpotency index at most 6, i.e. $T^6 = 0$ holds. Recall that these triples are the objects of the category $\mathcal{S}(6)$. But first we study a related category $\mathcal{S}(\tilde{6})$.

1. The Category $\mathcal{S}(\tilde{6})$

Let $\mathcal{H}(\tilde{6})$ be the category of all (finite dimensional) representations of \tilde{Q} which satisfy the commutativity relations $\beta\alpha' = \alpha\beta$ and the nilpotence conditions $\alpha^6 = 0 = (\alpha')^6$, thus, using notation from (0.2), $\mathcal{H}(\tilde{6}) = \mathcal{H}(kA_\infty/\alpha^6)$. Clearly the category $\mathcal{S}(\tilde{6})$, which we are going to describe in this section, is the full subcategory of $\mathcal{H}(\tilde{6})$ of all representations for which the maps β are monomorphisms. The category $\mathcal{H}(\tilde{6})$ will be used as a general reference category, its Grothendieck group $K_0(\mathcal{H}(\tilde{6}))$ (of all objects modulo exact sequences) will be denoted just by K_0 . Note that K_0 is free abelian with basis $\mathbf{e}(z)$, where z is a vertex of \tilde{Q} . If M is a representation of \tilde{Q} , we will denote by $\mathbf{dim} M$ the corresponding element in K_0 and call it its *dimension vector*. Given a dimension vector \mathbf{d} , the coefficient with index z (here, z is a vertex of \tilde{Q}) will be denoted by \mathbf{d}_z .

We consider first the full subcategory $\mathcal{C} \subseteq \mathcal{H}(\tilde{6})$, which has as objects those representations M which satisfy

- (a) $M_z = 0$ and $M_{z'} = 0$ for all $z \in \{-1, -2, \dots\}$ and
- (b) the maps $M(\beta_0)$ and $M(\beta_1)$ are the identity maps.

When dealing with \mathcal{C} , we do not have to mention the vertices $0'$ and $1'$, as the maps $\alpha'_1 = \alpha_1$ and $\alpha'_2 = \alpha_2\beta_2$ can be recovered. In fact, the category \mathcal{C} is equivalent to the category of representations of the quiver

$$\begin{array}{ccccccc}
 & & 2' & \xleftarrow{\alpha'} & 3' & \xleftarrow{\alpha'} & 4' & \xleftarrow{\quad} & \dots \\
 & & \circ & & \circ & & \circ & & \\
 & & \downarrow \beta & & \downarrow \beta & & \downarrow \beta & & \\
 \circ & \xleftarrow{\alpha} & \circ & \xleftarrow{\alpha} & \circ & \xleftarrow{\alpha} & \circ & \xleftarrow{\quad} & \dots \\
 0 & & 1 & & 2 & & 3 & & 4
 \end{array}$$

with commutativity relations $\beta\alpha' = \alpha\beta$ and nilpotence conditions $(\alpha')^6 = \alpha^6 = 0$. In order to stress that we consider a full subcategory of $\mathcal{H}(\tilde{6})$, we insert the numbers $\mathbf{d}_{0'} = \mathbf{d}_0$ and $\mathbf{d}_{1'} = \mathbf{d}_1$ when we display the dimension vector \mathbf{d} of a representation of this quiver; for example, the dimension vector of the indecomposable projective representation corresponding to the vertex 3 will be displayed as $\begin{smallmatrix} 11000\dots \\ 11110\dots \end{smallmatrix}$, or just as $\begin{smallmatrix} 1100 \\ 1111 \end{smallmatrix}$ (we only will exhibit dimension vectors \mathbf{d} for representations of \tilde{Q} which start on the left with the numbers $\mathbf{d}_{0'}$ and \mathbf{d}_0).

(1.1) The tubular algebra Θ . An essential part of the category \mathcal{C} , and hence of $\mathcal{S}(\tilde{6})$, consists of modules over the finite dimensional algebra Θ which is given

by the following subquiver of \tilde{Q} ,

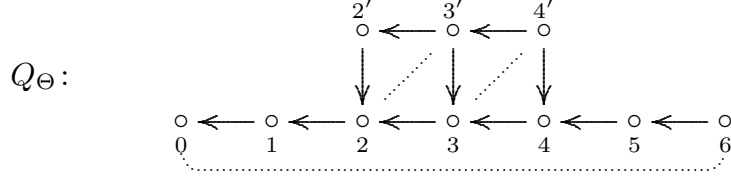

with relations indicated as usual: Two commutativity relations and one zero relation. The algebra Θ is tubular, as we are going to show.

Denote by Θ_0 the algebra obtained from Θ by deleting the vertices $4'$ and 6 , this is a tame concealed algebra of type \tilde{E}_7 . In order to see this, one may use the Happel-Vossieck list (see for example [9], page 365), or one may define directly a tilting functor by forming the pushout of the commutative square, thus replacing the vertex $3'$ and the four arrows between $3'$ and 2 by a new vertex $3''$ with arrows $2' \rightarrow 3''$, $3 \rightarrow 3''$, and $3'' \rightarrow 2$.

We denote by $\mathcal{P}(\Theta_0)$ and $\mathcal{Q}(\Theta_0)$ the preprojective and the preinjective component of the Auslander-Reiten quiver $\Gamma(\Theta_0)$ of Θ_0 , respectively. The remaining indecomposable Θ_0 -modules occur in a $\mathbb{P}_1(k)$ -family $\mathcal{T}(\Theta_0)$ of tubes of tubular type $(4, 3, 2)$. Almost all of the tubes are homogeneous, but there are three large tubes of rank 2, 3, and 4, respectively. Here we picture the mouth for each of these three tubes.

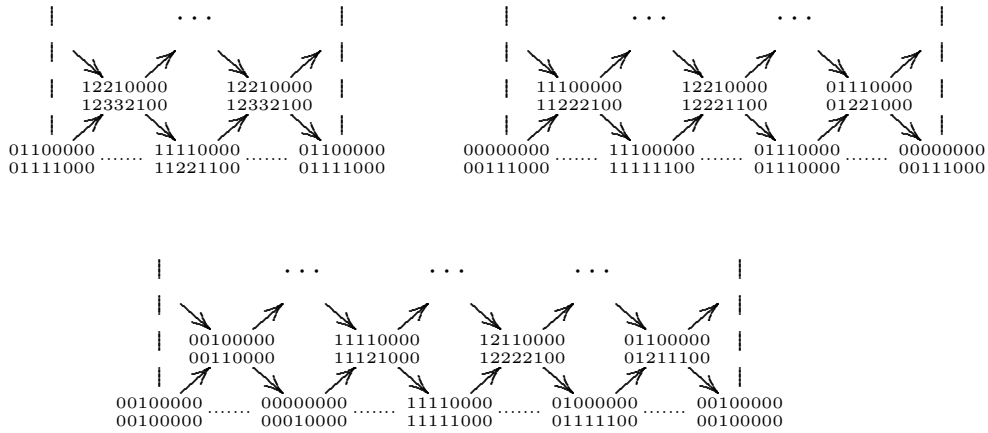

Denote by R the radical of the projective Θ -module $P_\Theta(6)$ and by R' the radical of the projective Θ -module $P_\Theta(4')$, both considered as Θ_0 -modules. These modules R, R' are indecomposable and the dimension vector of R is $\begin{smallmatrix} 010000 \\ 011111 \end{smallmatrix}$, that of R' is $\begin{smallmatrix} 11110 \\ 11111 \end{smallmatrix}$ (here we use already the convention mentioned above). As both R and R' are modules on the mouth of the 4-tube, Θ is obtained from Θ_0 as a two-fold one-point extension of a tame concealed algebra and hence is a tubular algebra of tubular type $(6, 3, 2)$ ([9], Chapter 5). The mouth of the big tube for

INVARIANT SUBSPACES OF NILPOTENT LINEAR OPERATORS. I.

Θ_0 after the twofold ray insertion looks as follows.

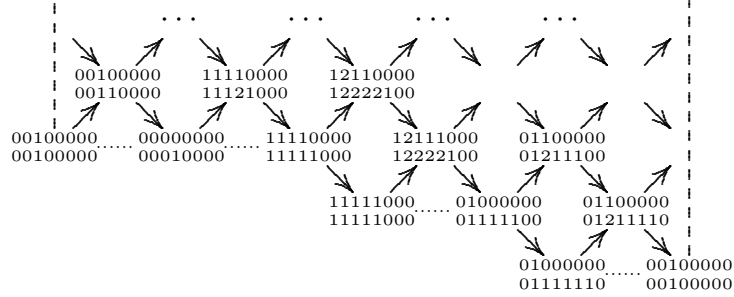

Since Θ is a tubular algebra, there is a second tame concealed algebra involved, usually denoted by Θ_∞ ; it is obtained from Θ by deleting the vertex 0 and has type \tilde{E}_8 . The regular Θ_∞ -modules form a $\mathbb{P}_1(k)$ -family of tubes of tubular type $(5, 3, 2)$. The tubes of rank 2 and 3 are obtained from the corresponding tubes in $\mathcal{T}(\Theta_0)$ by replacing each representation M by $M[1]$; here is the mouth of the tube of rank 5.

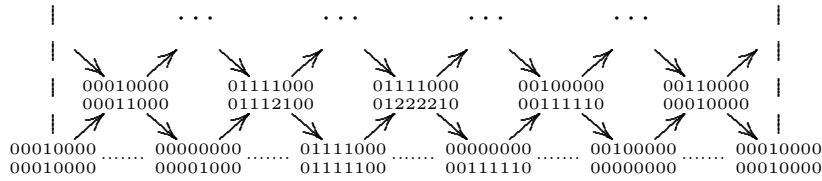

The shape of the category of Θ -modules is as follows:

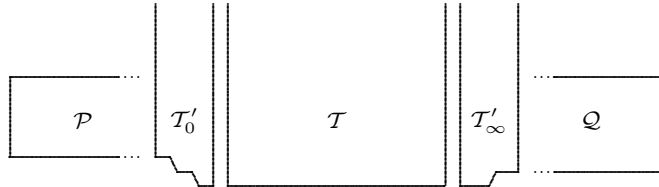

Here, \mathcal{P} is $\mathcal{P}(\Theta_0)$ and \mathcal{T}'_0 is obtained from $\mathcal{T}(\Theta_0)$ by the two-fold ray insertion in the 4-tube at the modules R and R' . Next, \mathcal{T} is the union of countably many stable tubular families \mathcal{T}_γ indexed by $\gamma \in \mathbb{Q}^+$, each \mathcal{T}_γ is a $\mathbb{P}_1(k)$ -family of tubes of type $(6, 3, 2)$. From the Auslander-Reiten quiver for Θ_∞ we obtain the preinjective component $\mathcal{Q} = \mathcal{Q}(\Theta_\infty)$ for Θ and the tubular family \mathcal{T}'_∞ , which arises from the tubular family $\mathcal{T}(\Theta_\infty)$ for Θ_∞ by the insertion of a coray in the 5-tube, as pictured below. Thus, there are two non-stable tubes in the category of Θ -modules, one in the family of tubes \mathcal{T}'_0 , the other one in \mathcal{T}'_∞ .

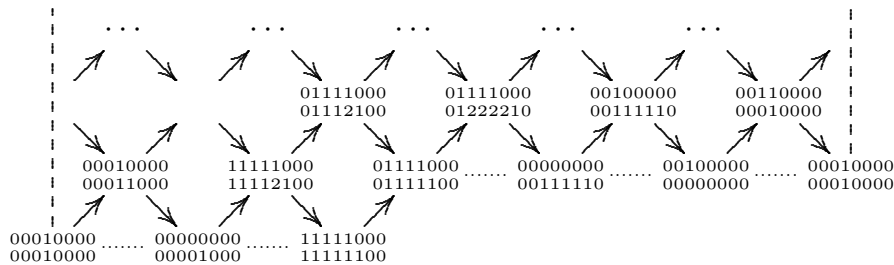

In the sequel we will want to locate indecomposable modules within the category of Θ -modules, and for this the index functions ι_0 and ι_∞ for the tubular algebra Θ can be used, they map the dimension vector of a module to its dot-product with with $\begin{smallmatrix} 0 & 0 & 1 & 1 & 0 & 0 & 0 & 0 \\ -1 & -1 & -1 & 0 & 1 & 1 & 0 & 0 \end{smallmatrix}$ and $\begin{smallmatrix} 0 & 0 & 0 & 1 & 1 & 0 & 0 & 0 \\ 0 & -1 & -1 & -1 & 0 & 1 & 1 & 0 \end{smallmatrix}$, respectively. We recall from [9], Section 5.2, that an indecomposable Θ -module with dimension vector \mathbf{d} is

in	\mathcal{P}	\mathcal{T}'_0	$\mathcal{T}_\gamma, \gamma \in \mathbb{Q}^+$	\mathcal{T}'_∞	\mathcal{Q}	$\mathcal{T}''_\infty, \mathcal{U}$	\mathcal{C}''
if	$\iota_0 < 0$	$\iota_0 = 0$	$\gamma = -\frac{\iota_0}{\iota_\infty}$	$\iota_0 > 0$	$\iota_0 \geq 0$	$\iota_0 > 0$	$\iota_\infty = \iota_0 = 0$
	and	and	and	and	and	and	or
	$\iota_\infty \leq 0$	$\iota_\infty < 0$	$\iota_\infty < 0$	$\iota_\infty = 0$	$\iota_\infty > 0$	$\iota_\infty = 0$	$\iota_\infty > 0$

where we use the abbreviations $\iota_0 = \iota_0(\mathbf{d})$ and $\iota_\infty = \iota_\infty(\mathbf{d})$. (We will come back to the right two columns of the table below.) This finishes our description of the tubular algebra Θ .

(1.2) The category \mathcal{C} . We obtain \mathcal{C} from the category of Θ -modules by repeatedly forming one-point extensions. Note that $\text{rad } P(5')$ with dimension vector $\begin{smallmatrix} 111110 \\ 111111 \end{smallmatrix}$ and $\text{rad } P(7)$ with dimension vector $\begin{smallmatrix} 0000000 \\ 0011111 \end{smallmatrix}$ both belong to the big tube in \mathcal{T}'_∞ , thus we can form the corresponding ray extensions and obtain a component of the following form for the two-fold one-point extension algebra Θ' of the algebra Θ .

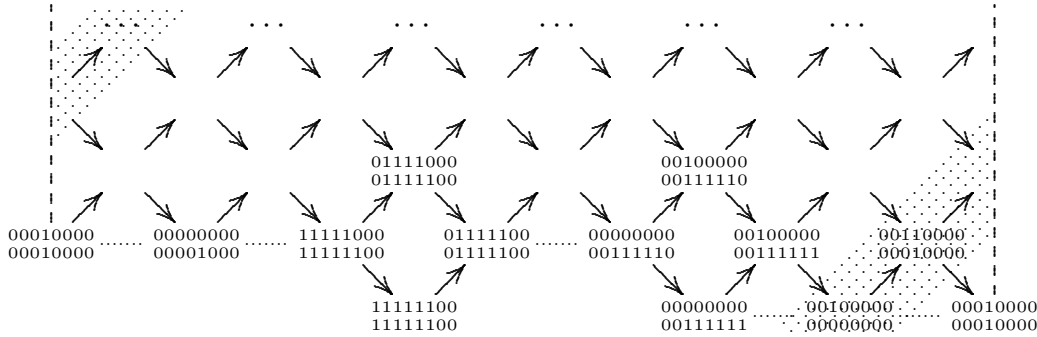

(The shaded area will be considered later.) We denote by \mathcal{T}''_∞ the one-parameter family of tubes obtained from \mathcal{T}'_∞ by forming these two ray extensions.

We claim that the category \mathcal{C} has the following shape

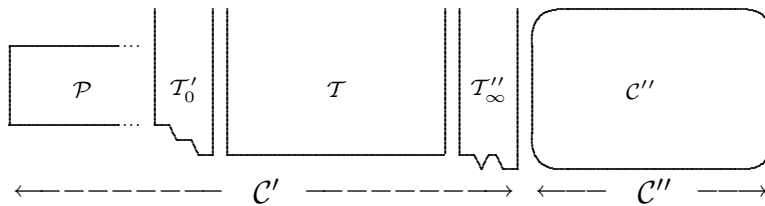

where $(\mathcal{C}', \mathcal{C}'')$ is a split torsion pair. *Proof:* For $t \geq 6$, we consider the full subcategory \mathcal{C}_t of \mathcal{C} formed by all modules with composition factors $S(r), S(q')$

where $0 \leq r \leq t$ and $0 \leq q \leq t - 2$. Of course, \mathcal{C}_6 is just the category of all Θ -modules, and \mathcal{C}_7 is the category of all Θ' -modules, where Θ' is obtained from Θ by forming the one-point extensions with respect to the two modules $\text{rad } P(5')$ and $\text{rad } P(7)$, as considered above. In general, \mathcal{C}_{t+1} is obtained from \mathcal{C}_t by forming the one-point extensions with respect to the two modules $\text{rad } P((t-1)')$ and $\text{rad } P(t+1)$. Inductively, we claim that \mathcal{C}_t has a split torsion pair $(\mathcal{C}'_t, \mathcal{C}''_t)$ with $\mathcal{C}'_t = \mathcal{C}'$ for $t \geq 7$. For $t = 7$, this follows from the fact that Θ' is obtained from Θ using two ray insertions in a tube in \mathcal{T}'_∞ . It remains to be noted that for $t \geq 7$, the modules $\text{rad } P((t-1)')$ and $\text{rad } P(t+1)$ belong to \mathcal{C}''_t . Indeed, an indecomposable module M in $\mathcal{C}_{t+1} \setminus \mathcal{C}_t$ is given — as a module over the two-fold one-point extension — by a homomorphism from a non-zero sum of copies of $\text{rad } P((t-1)')$ or $\text{rad } P(t+1)$ to a module in \mathcal{C}_t , which must be in \mathcal{C}''_t by induction. So M is in \mathcal{C}''_{t+1} .

As a byproduct of this result we can verify the information in the table about the extension of the index functions ι_0 and ι_∞ to the indecomposables in \mathcal{C} . First we observe that for each ray-inserted module M in \mathcal{T}''_∞ both conditions $\iota_0(\mathbf{dim } M) > 0$ and $\iota_\infty(\mathbf{dim } M) = 0$ are satisfied. Second, for an indecomposable module $M \in \mathcal{C}''$ which is a module over some iterated one-point extension of Θ , the restriction $\text{Res}_{Q_\Theta}(M)$ of M to Q_Θ is a (possibly empty) sum of modules in \mathcal{Q} .

(1.3) The category $\mathcal{C} \cap \mathcal{S}(\tilde{6})$. We start with the observation that a module $M \in \mathcal{C}$ which is not in $\mathcal{S}(\tilde{6})$ has the property that $\text{Hom}_{\mathcal{C}}(S(i'), M) \neq 0$ for at least one of the simple modules $S(i')$ where $i \geq 2$ is a natural number. Using the index functions we can locate the simple module $S(2')$ in the tubular family \mathcal{T}''_∞ , and all the simple modules $S(t')$ with $t \geq 3$ in the category \mathcal{C}'' . Thus, in \mathcal{C}' there is a single ray which contains modules not belonging to $\mathcal{S}(\tilde{6})$, namely the ray in \mathcal{T}''_∞ starting at $S(2')$, as shaded above. If we delete this ray, we obtain the following tube:

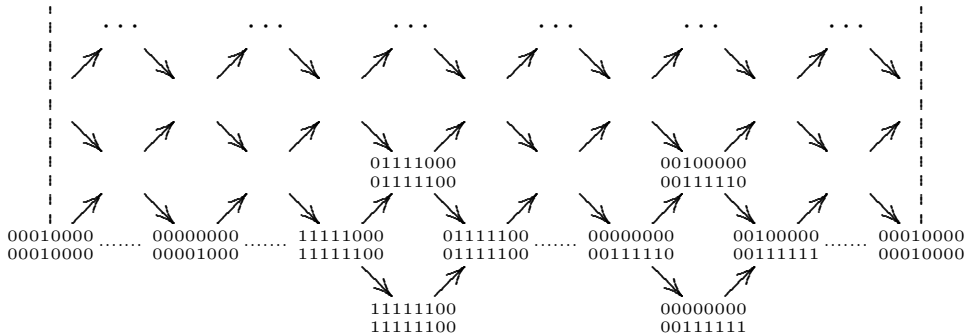

After the ray-deletion, the arrows in this tube represent irreducible maps in the category $\mathcal{S}(\tilde{6}) \cap \mathcal{C}$. Thus the tube becomes an Auslander-Reiten component for $\mathcal{S}(\tilde{6}) \cap \mathcal{C}$:

The functor Mono takes an object $B = (B' \xrightarrow{b} B'')$ in $\mathcal{H}(\tilde{n})$ to the embedding $\text{Mono}(B) = (\text{Im } b \xrightarrow{\text{incl}} B'')$ in $\mathcal{S}(\tilde{n})$. Then the canonical map $\text{can}: B \rightarrow$

$\text{Mono}(B)$ is a *minimal left $\mathcal{S}(\tilde{n})$ -approximation* for B , so can is left minimal and each test map $t: B \rightarrow C$ with $C \in \mathcal{S}(\tilde{n})$ factors over it. In the above tube in $\mathcal{C} \cap \mathcal{S}(\tilde{6})$, the arrows leaving the ray which is to be deleted represent maps of type $B \rightarrow \text{Mono}(B)$.

Let $0 \rightarrow A \rightarrow B \rightarrow C \rightarrow 0$ be an Auslander-Reiten sequence in \mathcal{C} which starts at an object $A \in \mathcal{C} \cap \mathcal{S}(\tilde{6})$ that is not relatively injective. We obtain the relative Auslander-Reiten sequence in $\mathcal{C} \cap \mathcal{S}(\tilde{6})$ as the lower sequence in the following diagram (cf. [11], Proposition 3.2).

$$\begin{array}{ccccccccc}
 0 & \longrightarrow & A & \longrightarrow & B & \longrightarrow & C & \longrightarrow & 0 \\
 & & \parallel & & \downarrow \text{can} & & \downarrow \text{can} & & \\
 0 & \longrightarrow & A & \longrightarrow & \text{Mono}(B) & \longrightarrow & \text{Mono}(C) & \longrightarrow & 0
 \end{array}$$

It follows that the ray deletion yields a component in the Auslander-Reiten quiver for $\mathcal{C} \cap \mathcal{S}(\tilde{6})$.

The two projective modules in this tube, $P(7)$ and $P(5')$, are projective and injective objects in the category $\mathcal{S}(\tilde{6})$, as we recall from [11], Proposition 1.4.

(1.3.1) Lemma. *Let Λ be a commutative uniserial ring and P a projective-injective Λ -module. The category $\mathcal{S}(\Lambda)$ has the following projective or injective objects:*

- (1) *The object $(P, 0)$ is projective-injective in $\mathcal{S}(\Lambda)$ and has the following source map and sink map*

$$(P, 0) \xrightarrow{\text{incl}} (P, \text{soc } P) \quad \text{and} \quad (\text{rad } P, 0) \xrightarrow{\text{incl}} (P, 0).$$

- (2) *The object (P, P) is projective-injective in $\mathcal{S}(\Lambda)$ and has the following source map and sink map*

$$(P, P) \xrightarrow{\text{can}} (P/\text{soc } P, P/\text{soc } P) \quad \text{and} \quad (P, \text{rad } P) \xrightarrow{\text{incl}} (P, P).$$

Denote by \mathcal{U} the intersection of \mathcal{T}_∞'' with $\mathcal{S}(\tilde{6})$, i.e. \mathcal{U} is obtained from \mathcal{T}_∞'' by deleting one ray in the tube of rank 6, as illustrated above. Then the category $\mathcal{C} \cap \mathcal{S}(\tilde{6})$ has the following shape:

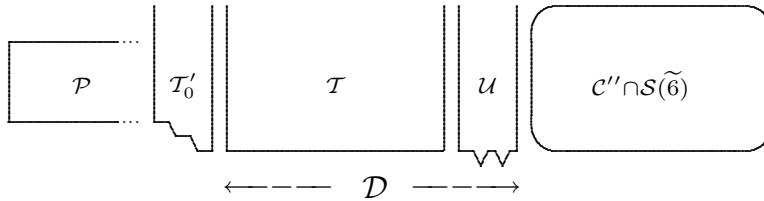

We will see in the next section that $\mathcal{D} = \mathcal{T} \sqcup \mathcal{U}$ is a fundamental domain for $\mathcal{S}(\tilde{6})$ under the shift. For further reference, let us introduce the following notation:

Denote by \mathcal{D}' the objects in \mathcal{D} which are Θ -modules. Let \mathcal{D}'' be the class of the remaining indecomposable objects in \mathcal{D} ; they form two rays in the non-stable tube: one ray consists of all the indecomposable objects M in \mathcal{D} with $M_{5'} \neq 0$, the other consists of all the indecomposable objects M in \mathcal{D} with $M_7 \neq 0$. The dimension vectors of the objects in \mathcal{D}'' will be discussed in (1.6).

(1.4) The fundamental domain for $\mathcal{S}(\tilde{6})$ under the shift. It is the part $\mathcal{D} = \mathcal{T} \sqcup \mathcal{U}$ which is of interest for us, since it will turn out that \mathcal{D} is a fundamental domain for the shift on \tilde{Q} and that the structure of $\mathcal{S}(\tilde{6})$ is as follows:

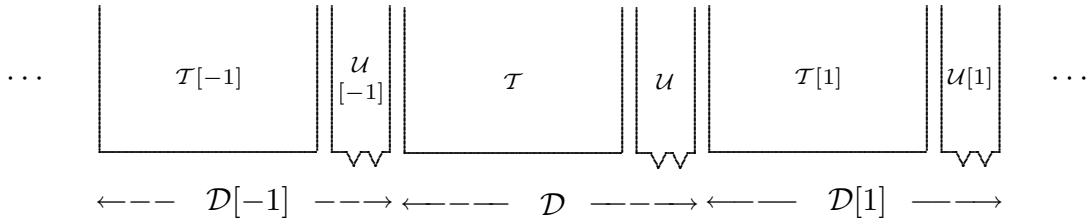

(1.4.1) Theorem. *For each indecomposable representation M in $\mathcal{S}(\tilde{6})$ there is a unique integer n such that $M[n]$ is in \mathcal{D} .*

Proof: Let $M \in \text{ind } \mathcal{S}(\tilde{6})$ be such that $M_i = 0$ for all $i < 0$ and that $M_0 \neq 0$. The existence of n as in the Theorem is a consequence of the following five claims. In the first three claims we show that either M , $M[1]$, or $M[2]$ occurs in $\mathcal{C}' \cap \mathcal{S}(\tilde{6}) = \mathcal{P} \sqcup \mathcal{T}'_0 \sqcup \mathcal{T} \sqcup \mathcal{U}$; in the last two claims we verify that each module in $\mathcal{P} \sqcup \mathcal{T}'_0$ has a translate in $\mathcal{D} = \mathcal{T} \sqcup \mathcal{U}$. We conclude the proof of the Theorem by verifying that the number n is indeed unique.

Claim 1. *If M has the property that β_0 is not surjective, then $M[2]$ is in \mathcal{C}' .*

Proof: For M such that β_0 is not surjective, consider the subrepresentation $N = (\sum M_{i'})$ of M generated by the elements in $\sum_{i \in \mathbb{Z}} M_{i'}$. The factor M/N has the following properties: For each $i \in \mathbb{Z}$, $(M/N)_{i'} = 0$ and $(M/N)_i = M_i / \text{Im}(\beta_i)$. In particular, $(M/N)_0$ is non-zero. Viewing M/N as a representation for the full subquiver of \tilde{Q} consisting of all points $\{i : i \in \mathbb{Z}\}$, we see that there is a non-zero map into the injective representation $P(5)$ for this subquiver. The representation $(M/N)[2]$ has the property that β_0 and β_1 are identity maps, and hence the composition $M[2] \rightarrow (M/N)[2] \rightarrow P(7)$ is a non-zero map in \mathcal{C} . Since $P(7)$ is in \mathcal{C}' , so is $M[2]$. ✓

Claim 2. *If M is such that β_0 is an isomorphism and β_1 is not surjective, then $M[1]$ is in \mathcal{C}' .*

This assertion can be shown in a similar way. ✓

Claim 3. *If M is such that both β_0 and β_1 are isomorphisms then M is in \mathcal{C}' .*

Proof: If both β_0 and β_1 are isomorphisms, then M is in \mathcal{C} . Since $M_0 \neq 0$ there is a non-zero map $M \rightarrow I(0) = P(5')$ to the injective envelope of $S(0)$, so M is in \mathcal{C}' . ✓

Claim 4. *The whole tubular family \mathcal{T}'_0 belongs to $\mathcal{U}[-1]$.*

As a consequence, we can use the notation $\mathcal{T}_0 = \mathcal{U}[-1]$.

Proof: We denote by $\mathbf{h}^0 = \begin{smallmatrix} 122100 \\ 123321 \end{smallmatrix}$ the radical generator in the Grothendieck group $K_0(\text{mod } \Theta_0)$ (we use here an upper index, since one of the vertices of the quiver is denoted by 0, thus there could arise some confusion). The representations in \mathcal{T}'_0 with dimension vector a multiple of \mathbf{h}^0 are in 1-1 correspondence via the shift $M \mapsto M[1]$ to the representations in \mathcal{U} of dimension type $\mathbf{h}^\infty = \begin{smallmatrix} 0122100 \\ 0123321 \end{smallmatrix}$. (Each module M in \mathcal{U} with dimension vector a multiple of \mathbf{h}^∞ has an isomorphism at β_2 since this map must be monic because the only modules in \mathcal{C}' with dimension vector a multiple of \mathbf{h}^∞ which do not have a monic map at β_2 occur in the ray starting at $S(2')$, which we have deleted.) Moreover, each module M on the mouth of one of the three large tubes in \mathcal{T}'_0 has its translate $M[1]$ in the corresponding big tube in \mathcal{U} , see the diagram above. Since each tube is path closed, we conclude that \mathcal{T}'_0 is contained in \mathcal{U} . \checkmark

Claim 5. *Each representation in \mathcal{P} has a translate in \mathcal{D} .*

Proof: First, let us specify the shape of \mathcal{P} including some of the dimension vectors (as we have mentioned before, we always specify the numbers \mathbf{d}_s and $\mathbf{d}_{s'}$ with $0 \leq s \leq t$ for a suitable t). We indicate also to which subcategories $\mathcal{U}[t]$ or $\mathcal{T}[t]$ the modules belong:

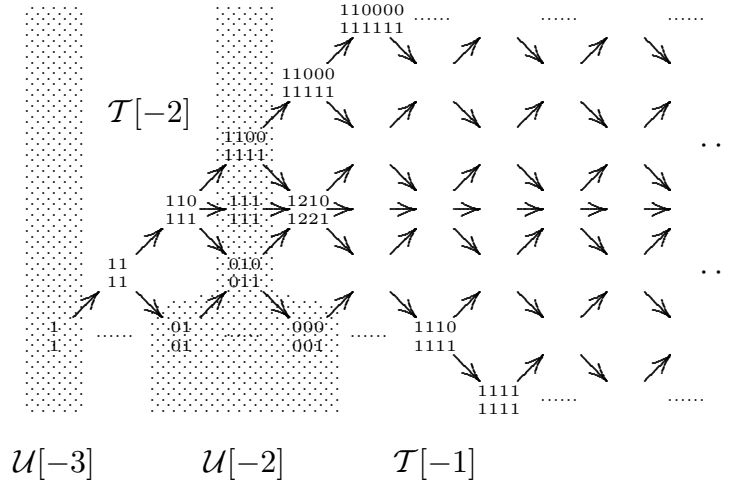

For each module $M \in \mathcal{P}$ the index functions ι_0 and ι_∞ can be used to specify the tubular family of M . Here we show that most of the modules in \mathcal{P} occur in $\mathcal{T}[-1]$. Let $M \in \mathcal{P}$ be such that there is a path $X \rightarrow \dots \rightarrow M$ where $X \in \mathcal{P}$ is one of the modules with dimension vector $\begin{smallmatrix} 11000 \\ 11111 \end{smallmatrix}$ or $\begin{smallmatrix} 1210 \\ 1221 \end{smallmatrix}$, and hence $X \in \mathcal{T}_{\frac{1}{2}}[-1]$ or $X \in \mathcal{T}_{\frac{1}{4}}[-1]$, respectively, and also a path from M to one of the modules Y on the mouth of some tube in \mathcal{T}'_0 . So we obtain a path (i.e. a sequence of non-zero homomorphisms between indecomposable modules)

$$X[1] \rightarrow \dots \rightarrow M[1] \rightarrow \dots \rightarrow Y[1]$$

with $X[1]$ in $\mathcal{T}_{\frac{1}{2}}$ or in $\mathcal{T}_{\frac{1}{4}}$ and $Y[1]$ in \mathcal{U} ; since \mathcal{D} is path closed, M is in $\mathcal{T}[-1]$. \checkmark

In order to finish the proof of Theorem (1.4.1) we verify that at most one translate of an indecomposable module M occurs in \mathcal{D} . Assume that an indecomposable object M is such that both M and $M[i]$ occur in \mathcal{D} for some $i > 0$. Then there is a path

$$X \rightarrow \cdots \rightarrow M \rightarrow \cdots \rightarrow M[i] \rightarrow \cdots \rightarrow Y$$

where $X \in \mathcal{T}'_0$ and $Y \in \mathcal{U}$. Hence there is a path

$$X[1] \rightarrow \cdots \rightarrow M[1] \rightarrow \cdots \rightarrow M[i] \rightarrow \cdots \rightarrow Y$$

where $X[1] \in \mathcal{U}$ by Claim 4. Since \mathcal{U} is path closed, $M[1]$ and $M[i]$ are in \mathcal{U} . A quick glance back at the index functions shows that $\iota_0(M) = \iota_\infty(M[1]) = 0$, contradicting our assumption that M is in \mathcal{D} . \checkmark

(1.5) The Auslander-Reiten quiver for $\mathcal{S}(\tilde{6})$.

(1.5.1) Theorem. *Each Auslander-Reiten sequence in the category $\mathcal{C} \cap \mathcal{S}(\tilde{6})$ with modules in \mathcal{D} is an Auslander-Reiten sequence in the category $\mathcal{S}(\tilde{6})$.*

Proof: We show that each source map $f : X \rightarrow Y$ in \mathcal{C} with $X \in \mathcal{D}$ is left almost split in $\mathcal{S}(\tilde{6})$. Let $T \in \text{ind } \mathcal{S}(\tilde{6})$ be a module and $t \in \text{Hom}_{\mathcal{S}}(X, T)$ a non-isomorphism. Then either T is in \mathcal{C} and hence t factors over f , or else by Theorem (1.4.1), there is a positive integer j such that the shifted representation $T[j]$ is in \mathcal{D} , so $\text{Hom}_{\mathcal{S}}(X, T) = \text{Hom}_{\mathcal{C}}(X[j], T[j]) = 0$ since $X[j]$ is in \mathcal{C}'' and $(\mathcal{C}', \mathcal{C}'')$ is a split torsion pair; thus, $t = 0$. \checkmark

In our main result we verify that the overall structure of the category $\mathcal{S}(\tilde{6})$ is as described in the introduction. Consider the following total ordering on the index set $I = \mathbb{Z} \times \mathbb{Q}_0^+$: Let $(m, \gamma) < (m', \gamma')$ if either $m < m'$ or $m = m'$ and $\gamma < \gamma'$ hold and define $\mathcal{T}_\mu = \mathcal{T}_\gamma[m]$ for $\mu = (m, \gamma) \in I$. We have seen that $\text{ind } \mathcal{S}(\tilde{6})$ is the union $\bigsqcup_{\mu \in I} \mathcal{T}_\mu$.

(1.5.2) Theorem. *For each $\mu \in I$, the category \mathcal{T}_μ is a $\mathbb{P}_1(k)$ -family of tubes of type $(6, 3, 2)$, separating $\mathcal{P}_\mu = \bigsqcup_{\lambda < \mu} \mathcal{T}_\lambda$ from $\mathcal{Q}_\mu = \bigsqcup_{\lambda > \mu} \mathcal{T}_\lambda$ in the sense that there is no non-zero map from \mathcal{T}_μ to \mathcal{P}_μ , nor from \mathcal{Q}_μ to \mathcal{T}_μ or \mathcal{P}_μ , nor between different tubes in \mathcal{T}_μ , and that each map from \mathcal{P}_μ to \mathcal{Q}_μ factors through each of the tubes in \mathcal{T}_μ .*

In the proof we will use left \mathcal{C} -approximations. For $M \in \mathcal{S}(\tilde{6})$ the minimal left \mathcal{C} -approximation $M \rightarrow {}^{\mathcal{C}}M$ is given by the obvious map:

$$\begin{array}{ccc}
 \cdots M_{-1'} \xleftarrow{\alpha'_0} M_{0'} \xleftarrow{\alpha'_1} M_{1'} \xleftarrow{\alpha'_2} M_{2'} \cdots & \longrightarrow & M_0 \xleftarrow{\alpha_1} M_1 \xleftarrow{\alpha_2 \beta_2} M_2 \cdots \\
 \downarrow \beta_{-1} \quad \downarrow \beta_0 \quad \downarrow \beta_1 \quad \downarrow \beta_2 & & \parallel \quad \parallel \quad \downarrow \beta_2 \\
 \cdots M_{-1} \xleftarrow{\alpha_0} M_0 \xleftarrow{\alpha_1} M_1 \xleftarrow{\alpha_2} M_2 \cdots & & M_0 \xleftarrow{\alpha_1} M_1 \xleftarrow{\alpha_2} M_2 \cdots
 \end{array}$$

Note that if $M \in \bigsqcup_{m < 0} \text{ind } \mathcal{D}[m]$ then the object ${}^c M$ in \mathcal{C} is a (sum of) modules in $\mathcal{P} \sqcup \mathcal{T}'_0$

Proof: Let us first consider the tubes in a given category \mathcal{T}_μ . We claim that each tubular family is a $\mathbb{P}_1(k)$ -family of tubes of tubular type $(6, 3, 2)$. Indeed, \mathcal{U} being obtained from the category of regular modules over a tilted algebra inherits its tubular type and the parameter set $\mathbb{P}_1(k)$ for the tubes from the corresponding hereditary algebra; and the study of wing extensions in [9], Section 3.4, and the categorical equivalences induced by the shrinking functors in [9], Section 5.4.3, imply that \mathcal{T}_1 , and hence each \mathcal{T}_γ , consists of a $\mathbb{P}_1(k)$ -family of tubes of the same tubular type $(6, 3, 2)$ ([9], Section 5.6).

It remains to check the separation properties. To simplify the notation we assume that $\mu \in I$ is such that \mathcal{T}_μ consists of modules in \mathcal{D} . The separation properties for test modules in \mathcal{D} follow from the corresponding properties for modules over the tubular algebra Θ . Let $M \in \mathcal{T}_\mu$, $M' \in \mathcal{D}[m']$, and $M'' \in \mathcal{D}[m'']$ where $m' < 0 < m''$. Using the fact shown above that $(\mathcal{C}', \mathcal{C}'')$ is a split torsion pair, it follows that there is no non-zero map $M'' \rightarrow M$ and — as in the proof of Theorem (1.5.1) — that there is no non-zero map $M \rightarrow M'$. Moreover, any map $f : M' \rightarrow M''$ in $\mathcal{S}(\tilde{6})$ factors over the left \mathcal{C} -approximation $M' \rightarrow {}^c M'$ and over the inclusion $\text{Res}_{Q_\Theta}(M'') \rightarrow M''$: Since ${}^c M'$ is a sum of modules in $\mathcal{P} \sqcup \mathcal{T}'_0$ and since $\text{Res}_{Q_\Theta}(M'')$ is preinjective, f factors through a sum of modules in the tube of M in \mathcal{T}_μ ([9], Section 5.2.2). \checkmark

(1.6) The dimension vectors of the indecomposable objects. Let χ be the quadratic form for the quiver \tilde{Q} together with the commutativity and the nilpotency relations, and $(-, -)$ the corresponding bilinear form. Thus χ and $(-, -)$ are defined on K_0 . (The bilinear form is defined as follows: $2(\mathbf{e}(z), \mathbf{e}(z')) = 1$ for $z = z'$, as well as if $\{z, z'\}$ is equal to $\{i, i+6\}$, $\{i', (i+6)'\}$ or $\{i, (i+1)'\}$; $2(\mathbf{e}(z), \mathbf{e}(z')) = -1$ in case $\{z, z'\}$ is equal to $\{i, i+1\}$, $\{i', (i+1)'\}$ or $\{i, i'\}$, and $(\mathbf{e}(z), \mathbf{e}(z')) = 0$ otherwise; here, i denotes an integral number.)

Given a dimension vector \mathbf{x} , denote by $t(\mathbf{x})$ the number of indexes $i \in \mathbb{Z}$ such that $\mathbf{x}_i \neq 0$; thus in case \mathbf{x} is the dimension vector of some object in $\mathcal{S}(\tilde{6})$, then $t(\mathbf{x})$ measure the size of the support of the total space. Note that for indecomposable objects M in $\mathcal{S}(\tilde{6})$, we always have $t(\mathbf{dim } M) \leq 8$, and all the indecomposable objects with $t(\mathbf{dim } M) = 8$ belong to some shift of \mathcal{D}'' .

(1.6.1) Theorem. *Let M be an indecomposable object in $\mathcal{S}(\tilde{6})$ and put $\mathbf{x} = \mathbf{dim } M$. Then*

$$\chi(\mathbf{x}) = \begin{cases} 0 & \text{if } \mathbf{x} \in \langle \mathbf{h}^0, \mathbf{h}^\infty \rangle \\ 2 & \text{if } t(\mathbf{x}) = 8 \\ 1 & \text{otherwise.} \end{cases}$$

Proof: Since χ is invariant with respect to the shift, we can assume that M belongs to \mathcal{D} . If M is a Θ -module (thus in \mathcal{D}'), then $\chi(\mathbf{x}) = \chi_\Theta(\mathbf{x})$ and we can use the known information about the quadratic form χ_Θ : we have $\chi_\Theta(\mathbf{x}) = 0$

INVARIANT SUBSPACES OF NILPOTENT LINEAR OPERATORS. I.

in case \mathbf{x} belongs to the radical of χ_Θ , thus if and only if $\mathbf{x} \in \langle \mathbf{h}^0, \mathbf{h}^\infty \rangle$, and $\chi_\Theta(\mathbf{dim} M) = 1$ for the remaining indecomposable Θ -modules.

Thus it remains to consider M in \mathcal{D}'' . As we know, \mathcal{D}'' consists of two rays in the non-stable tube of \mathcal{U} : either $M_{5'} \neq 0$ or $M_7 \neq 0$ (and not both). We deal with these two rays separately.

First consider the ray starting at $P(5')$, say

$$P(5') = P(5')\{1\} \rightarrow P(5')\{2\} \rightarrow P(5')\{3\} \rightarrow \dots .$$

Let $R' = \text{rad } P(5')$ and consider the ray starting in R' , say

$$R' = R'\{1\} \rightarrow R'\{2\} \rightarrow R'\{3\} \rightarrow \dots .$$

Note that $\mathbf{dim} P(5')\{i\} = \mathbf{dim} R'\{i\} + \mathbf{e}(5')$. The first six objects $R'\{1\}, \dots, R'\{6\}$ have dimension vectors

$$\begin{array}{cccccccc} 11111000 & \rightarrow & 01111000 & \rightarrow & 01111000 & \rightarrow & 01211000 & \rightarrow & 01221000 & \rightarrow & 01221000 & \rightarrow & \dots \\ 11111100 & & 01111100 & & 01222210 & & 01222210 & & 01232210 & & 01233210 & & \dots \end{array}$$

the further dimension vectors are obtained by adding multiples of $\mathbf{h}^\infty = \begin{smallmatrix} 01221000 \\ 01233210 \end{smallmatrix}$. Note that

$$\chi(\mathbf{x} + \mathbf{e}(5')) = \chi(\mathbf{x}) + 1 + 2(\mathbf{x}, \mathbf{e}(5'))$$

If $\mathbf{x} = \mathbf{dim} R'\{i\}$ with $1 \leq i \leq 5$, then $\chi(\mathbf{x}) = 1$ and $\mathbf{x}_{4'} = 1$, and $\mathbf{x}_4 = \mathbf{x}_5$. This shows that $\chi(\mathbf{x} + \mathbf{e}(5')) = 1$ in these cases. For $\mathbf{x} = \mathbf{dim} R'\{6\} = \mathbf{h}^\infty$, we have $\chi(\mathbf{x}) = 0$ and $(\mathbf{x}, \mathbf{e}(5')) = 0$, thus also here we have $\chi(\mathbf{x} + \mathbf{e}(5')) = 1$. The fact that $(\mathbf{h}^\infty, \mathbf{e}(5')) = 0$ shows that $\chi(\mathbf{x}) = 1$ for all dimension vectors \mathbf{x} on the ray starting at $P(5')$.

Second, consider the ray starting at $P(7)$,

$$P(7) = P(7)\{1\} \rightarrow P(7)\{2\} \rightarrow P(7)\{3\} \rightarrow \dots .$$

Let $R = \text{rad } P(7)$ and consider the ray starting in R , say

$$R = R\{1\} \rightarrow R\{2\} \rightarrow R\{3\} \rightarrow \dots .$$

We have $\mathbf{dim} P(7)\{i\} = \mathbf{dim} R\{i\} + \mathbf{e}(7)$. The first six objects $R\{1\}, \dots, R\{6\}$ have dimension vectors

$$\begin{array}{cccccccc} 00000000 & \rightarrow & 00100000 & \rightarrow & 00110000 & \rightarrow & 00110000 & \rightarrow & 11221000 & \rightarrow & 01221000 & \rightarrow & \dots \\ 00111110 & & 00111110 & & 00121110 & & 00122110 & & 11233210 & & 01233210 & & \dots \end{array}$$

the further dimension vectors are again obtained by adding multiples of $\mathbf{h}^\infty = \begin{smallmatrix} 01221000 \\ 01233210 \end{smallmatrix}$. As in the previous case, we use the formula

$$\chi(\mathbf{x} + \mathbf{e}(7)) = \chi(\mathbf{x}) + 1 + 2(\mathbf{x}, \mathbf{e}(7)).$$

For the dimension vectors $\mathbf{x} = \mathbf{dim} R\{i\}$ with $1 \leq i \leq 5$, we have $\chi(\mathbf{x}) = 1$, whereas $\chi(\mathbf{dim} R\{6\}) = 0$. This time, we have $2(\mathbf{x}, \mathbf{e}(7)) = -1$ for $1 \leq i \leq 4$, but $2(\mathbf{x}, \mathbf{e}(7)) = 0$ for $5 \leq i \leq 6$. This implies that

$$\chi(\mathbf{dim} P(7)\{5\}) = 2, \text{ and } \chi(\mathbf{dim} P(7)\{i\}) = 1 \text{ for } i = 1, 2, 3, 4, 6.$$

Again, we have $(\mathbf{h}^\infty, \mathbf{e}(7)) = 0$, thus

$$\chi(\mathbf{dim} P(7)\{5 + 6n\}) = 2, \text{ and } \chi(\mathbf{dim} P(7)\{i + 6n\}) = 1 \text{ for } i = 1, 2, 3, 4, 6,$$

for all $n \in \mathbb{N}_1$.

Altogether we see: The two rays which form \mathcal{D}'' do not contain objects with dimension vector \mathbf{x} in $\langle \mathbf{h}^0, \mathbf{h}^\infty \rangle$. But they contain all the objects with $t(\mathbf{x}) = 8$. The objects M with $t(\mathbf{x}) = 8$ are just the objects of the form $P(7)\{5 + 6n\}$, and then $\chi(\mathbf{x}) = 2$. Otherwise $\chi(\mathbf{x}) = 1$. \checkmark

2. Coverings for Submodule Categories

In this section we show that the covering functor

$$\pi: \mathcal{S}(\tilde{n}) \rightarrow \mathcal{S}(n)$$

is dense in case $n \leq 6$. As a consequence, we can describe the overall structure of the submodule category $\mathcal{S}(6)$ and obtain a detailed picture for the indecomposable modules in the non-stable family of tubes.

(2.1) Coverings. The categories $\mathcal{S}(\tilde{n})$ and $\mathcal{S}(n)$ are contained in the categories $\mathcal{H}(\tilde{n})$ and $\mathcal{H}(n)$ of modules over the triangular matrix algebras with coefficients in $kA_\infty^\infty/\alpha^n$ and $k[x]/x^n$, respectively. These two categories are related by the covering functor

$$\pi: \mathcal{H}(\tilde{n}) \rightarrow \mathcal{H}(n)$$

which maps an object $(A' \xrightarrow{\beta} A) \in \mathcal{H}(\tilde{n})$ where $A = (A_i)$ and $A' = (A'_i)$ are kA_∞^∞ -modules to the map $(\bigoplus A'_i \xrightarrow{\text{diag } \beta} \bigoplus A_i) \in \mathcal{H}(n)$ where the $k[x]$ -module structure on $\bigoplus A_i$ and $\bigoplus A'_i$ is given by the operation of α on A and A' . The group \mathbb{Z} acts freely via the shift on the isoclasses of modules in $\mathcal{H}(\tilde{n})$. According to [6], Section 3, there is an injection from the \mathbb{Z} -orbits of isoclasses of indecomposable objects in $\mathcal{H}(\tilde{n})$ into the isoclasses of indecomposable objects in $\mathcal{H}(n)$.

Also the corresponding statement for the subobject categories $\mathcal{S}(\tilde{n})$ and $\mathcal{S}(n)$ holds:

(2.1.1) Proposition. *The subcategory $\mathcal{S}(\tilde{n})$ of $\mathcal{H}(\tilde{n})$ is closed under the operation of the group $G = \mathbb{Z}$. The restriction of the covering functor π to $\mathcal{S}(\tilde{n})$ maps an object into the corresponding subcategory $\mathcal{S}(n)$ of $\mathcal{H}(n)$. Hence $\pi|_{\mathcal{S}}$ induces an*

injection from the G -orbits of isoclasses of indecomposable objects in $\mathcal{S}(\tilde{n})$ into the isoclasses of indecomposable objects in $\mathcal{S}(n)$. \checkmark

$$\begin{array}{ccc} \mathcal{S}(\tilde{n}) & \xrightarrow{\text{incl}} & \mathcal{H}(\tilde{n}) \\ \pi|_{\mathcal{S}} \downarrow & & \downarrow \pi \\ \mathcal{S}(n) & \xrightarrow{\text{incl}} & \mathcal{H}(n) \end{array}$$

We are interested in the case when the injection given by $\pi|_{\mathcal{S}}$ in Proposition (2.1.1) is bijective. For this we adapt the definition of *locally support finite* to our situation.

Definition. The *support* $\text{supp } M$ of a representation $M \in \mathcal{H}(\tilde{n})$ is the set of all points z of the quiver \tilde{Q} for which $M_z \neq 0$ holds. The category $\mathcal{H}(\tilde{n})$ is said to be *locally support finite with respect to $\mathcal{S}(\tilde{n})$* provided the union

$$S_z = \bigcup \{ \text{supp } M : M \in \text{ind } \mathcal{S}(\tilde{n}) \text{ and } M_z \neq 0 \}$$

is a finite set for each point z in the quiver. For a set S of points in Q , we denote by S^+ the set of all points $y \in Q$ for which there exists a non-zero path to or from an element in S (thus, S^+ is the union of the supports of the projective and the injective indecomposable objects in $\mathcal{H}(\tilde{n})$ which correspond to a point in S). Note that if S is finite then so is S^+ .

(2.1.2) Theorem. *Assume that $\mathcal{H}(\tilde{n})$ is locally support finite with respect to $\mathcal{S}(\tilde{n})$. Then the restriction $\pi|_{\mathcal{S}}$ of the covering functor $\pi: \mathcal{H}(\tilde{n}) \rightarrow \mathcal{H}(n)$ induces a bijection between the G -orbits of isoclasses of indecomposables in $\mathcal{S}(\tilde{n})$ and the isoclasses of indecomposables in $\mathcal{S}(n)$.*

For the proof of Theorem (2.1.2) we use a lemma.

(2.1.3) Lemma. *Let S be a finite set of points in \tilde{Q} . Suppose that a locally finite dimensional module $A \in \mathcal{S}(\tilde{n})^{\text{lfd}}$ has the property that its restriction to S^+ decomposes in $\mathcal{H}(\tilde{n})$ as $\text{Res}_{S^+} A = B \oplus C$ where B has support in S . Then A itself has a decomposition $A = B \oplus D$ where $B \in \mathcal{S}(\tilde{n})$ and $D \in \mathcal{S}(\tilde{n})^{\text{lfd}}$.*

Clearly, $\mathcal{S}(\tilde{n})^{\text{lfd}}$ denotes the category of all locally finite dimensional representations of \tilde{Q} which satisfy the commutativity and nilpotency relations and the extra condition that all maps β_i are monic.

Proof of Lemma (2.1.3): If $\text{Res}_{S^+} A = B \oplus C$ is a decomposition as in the lemma, then the required module $D \in \mathcal{S}(\tilde{n})^{\text{lfd}}$ is constructed as in [5], Lemma 2: For each point $z \in Q$ put $D_z = C_z$ if $z \notin S^+$ and $D_z = A_z$ otherwise. Then D is a module in $\mathcal{H}(\tilde{n})$ satisfying $A = B \oplus D$. Clearly, $B \in \mathcal{S}(\tilde{n})$ and $D \in \mathcal{S}(\tilde{n})^{\text{lfd}}$. \checkmark

Proof of Theorem (2.1.2): We need to show that the restriction of the covering functor $\pi: \mathcal{S}(\tilde{n}) \rightarrow \mathcal{S}(n)$ is dense. Let $M = (V, U, T)$ be an indecomposable

object in $\mathcal{S}(n)$. The pull up (A, A') in $\mathcal{S}(\tilde{n})^{\text{ld}}$ is the locally finite dimensional representation such that $A_i = V$ and $A'_i = U$ for each i and such that the operation of each arrow α is given by T . Let z be a point of the quiver \tilde{Q} which is in the support of (A, A') . Since $\mathcal{H}(\tilde{n})$ is locally support finite with respect to $\mathcal{S}(\tilde{n})$, the set S_z and its extension S_z^+ are finite. Hence the restriction $\text{Res}_{S_z^+}(A, A')$ is a direct sum of indecomposable objects in $\mathcal{S}(\tilde{n})$. Let B be an indecomposable direct summand so that $B_z \neq 0$, then the support of B is contained in S_z . Hence B is an indecomposable finite dimensional direct summand of (A, A') , according to Lemma (2.1.3). It follows from [5], Lemma 1, that $M \cong \pi B$. \checkmark

Let \mathcal{S} be one of the categories $\mathcal{S}(n)$ or $\mathcal{S}(\tilde{n})$ and let \mathcal{H} be the corresponding module category $\mathcal{H}(n)$ or $\mathcal{H}(\tilde{n})$, respectively. We recall from [11], Proposition 3.2, how Auslander-Reiten sequences in the submodule category \mathcal{S} are constructed from the corresponding Auslander-Reiten sequences in \mathcal{H} . Consider the Mono-functor

$$\text{Mono}: \quad \mathcal{H} \rightarrow \mathcal{S}, \quad (B' \xrightarrow{b} B) \mapsto (\text{Im } b \xrightarrow{\text{incl}} B).$$

If $(A' \xrightarrow{a} A)$ is an object in \mathcal{S} which is not relatively injective in \mathcal{S} and if

$$0 \rightarrow (A' \xrightarrow{a} A) \rightarrow (B' \xrightarrow{b} B) \rightarrow (C' \xrightarrow{c} C) \rightarrow 0$$

is an Auslander-Reiten sequence in the module category \mathcal{H} , then the corresponding Auslander-Reiten sequence in the category \mathcal{S} is obtained by applying the functor Mono to the middle and end terms:

$$0 \rightarrow (A' \xrightarrow{a} A) \rightarrow (\text{Im } b \xrightarrow{\text{incl}} B) \rightarrow (\text{Im } c \xrightarrow{\text{incl}} C) \rightarrow 0$$

Since the covering functor $\pi: \mathcal{H}(\tilde{n}) \rightarrow \mathcal{H}(n)$ preserves Auslander-Reiten sequences, and since it commutes with the Mono-functor in the sense that the following diagram gives rise to an isomorphism for each object in $\mathcal{H}(\tilde{n})$,

$$\begin{array}{ccc} \mathcal{H}(\tilde{n}) & \xrightarrow{\pi} & \mathcal{H}(n) \\ \text{Mono} \downarrow & & \downarrow \text{Mono} \\ \mathcal{S}(\tilde{n}) & \xrightarrow{\pi|_{\mathcal{S}}} & \mathcal{S}(n) \end{array}$$

we obtain the following consequence.

(2.1.4) Proposition. *The covering functor $\mathcal{S}(\tilde{n}) \rightarrow \mathcal{S}(n)$ preserves Auslander-Reiten sequences.* \checkmark

In Lemma (1.3.1) we have obtained a description of the projective and the injective objects in \mathcal{S} and their sink and source maps. It follows that the covering functor $\mathcal{S}(\tilde{n}) \rightarrow \mathcal{S}(n)$ maps the projective and injective objects in $\mathcal{S}(\tilde{n})$

to the corresponding objects in $\mathcal{S}(n)$ and preserves their sink and source maps, respectively.

As a consequence of Theorem (2.1.2), of Proposition (2.1.4), and of the above remark we obtain the following relative version of [6], Theorem 3.6.

(2.1.5) Theorem. *The restriction of the covering functor $\pi|_{\mathcal{S}}: \mathcal{S}(\tilde{n}) \rightarrow \mathcal{S}(n)$ induces an isomorphism of the quotient $\Gamma(\tilde{n})/\mathbb{Z}$ of the Auslander-Reiten quiver $\Gamma(\tilde{n})$ of $\mathcal{S}(\tilde{n})$ modulo the shift onto the union of some connected components of the Auslander-Reiten quiver $\Gamma(n)$ of $\mathcal{S}(n)$. This functor $\pi|_{\mathcal{S}}$ is dense if $\mathcal{H}(\tilde{n})$ is locally support finite with respect to $\mathcal{S}(\tilde{n})$. \checkmark*

(2.2) The category $\mathcal{S}(6)$. First we observe that $\mathcal{H}(\tilde{6})$ is locally support finite with respect to $\mathcal{S}(\tilde{6})$.

(2.2.1) Lemma.

1. *The support of an indecomposable module in the non-stable tube in \mathcal{U} is contained in*

$$[0, \dots, 7] \cup [0', \dots, 5'].$$

2. *The support of an indecomposable object in a stable tube in \mathcal{U} is contained in*

$$[1, \dots, 6] \cup [1', \dots, 4'].$$

3. *The support of an indecomposable object in $\mathcal{T} = \bigsqcup_{\gamma \in \mathbb{Q}^+} \mathcal{T}_{\gamma}$ is contained in*

$$[0, \dots, 6] \cup [0', \dots, 4'].$$

Proof: The possible support of a module in the category $\mathcal{S}(\tilde{n})$ is determined by its position relatively to the projective and injective objects in the Auslander-Reiten quiver. We have located all the projective and injective modules in Section 1. \checkmark

The picture above Theorem (1.4.1) describes the overall structure of the category $\mathcal{S}(\tilde{6})$. According to Lemma (2.2.1) and Theorem (2.1.5), the covering functor $\mathcal{S}(\tilde{6}) \rightarrow \mathcal{S}(6)$ is dense. As a consequence, the indecomposable objects in $\mathcal{S}(6)$ are in one-to-one correspondence to the indecomposables in the fundamental domain \mathcal{D} and the Auslander-Reiten quiver for $\mathcal{S}(6)$ is obtained from the Auslander-Reiten quiver for $\mathcal{S}(\tilde{6})$ by identifying the shifted copies of \mathcal{D} . For each tubular family \mathcal{T}_{γ} , $\gamma \in \mathbb{Q}_0^+$, in \mathcal{D} , denote the image under the covering functor by $\bar{\mathcal{T}}_{\gamma}$. We arrange the tubular families along the unit circle by placing $\bar{\mathcal{T}}_{\gamma}$ for $\gamma = \frac{p}{q}$ at the point $e^{2\pi i \frac{p}{p+q}}$.

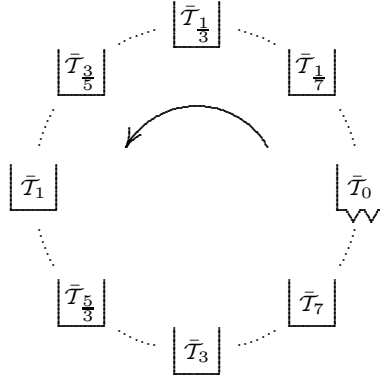

Thus, homomorphisms in the infinite radical of $\mathcal{S}(6)$ go counterclockwise, as indicated by the arrow. More precisely, the homomorphisms in the category $\mathcal{S}(n)$ can be computed from those in $\mathcal{S}(\tilde{n})$ by using the following formula.

(2.2.2) Lemma. *For $M, N \in \mathcal{H}(\tilde{n})$ there is an isomorphism of k -spaces*

$$\mathrm{Hom}_{\mathcal{H}(n)}(\pi M, \pi N) \cong \bigoplus_{g \in \mathbb{Z}} \mathrm{Hom}_{\mathcal{H}(\tilde{n})}(M, N[g]).$$

Proof: The assertion holds since the covering functor π is left adjoint to the pull up functor F_\bullet ([3], Section 3.2) and since there is a canonical isomorphism $F_\bullet \pi N \cong \bigoplus_{g \in \mathbb{Z}} N[g]$ ([6], Lemma 3.2.) \checkmark

(2.3) The non-stable tubular family. We conclude this section with a detailed picture of the tubes in $\bar{\mathcal{T}}_0$. We present an object (A, A') in $\mathcal{S}(n)$ as follows.

The $k[x]$ -module A has the form $A \cong \bigoplus_{i=1}^t k[x]/x^{\lambda_i}$ where the λ_i form a partition with all parts bounded by n . We picture A by rotating the Young diagram for the partition (λ_i) by 90° and by suitably adjusting the columns in height and order. The submodule A' is represented by the image of a set of generators: If one generator has a non-zero entry in the i -th summand of A , say the entry is in the j -th power of the radical, but not the $(j+1)$ -st power, then we put a symbol \bullet in the j -th box of the i -th column to indicate the entry x^j . Different entries, say cx^j where c is a unit, are indicated by writing the symbol c into the j -th box. Symbols belonging to the same generator of A' are connected by a line. In fact, we will arrange the columns of A in height and order in such a way that these connecting lines are horizontal and short, as good as possible.

Example. The only objects in \mathcal{D} where the total space has maximal support $[0, \dots, 7]$ occur in the non-stable tube in \mathcal{U} at each of the intersections of the ray starting at $P(7)$ with the coray ending at $P(5')$. The first such object M has dimension vector $\begin{smallmatrix} 11221000 \\ 11233211 \end{smallmatrix}$. Let $(A, A') = \pi(M)$ be the corresponding object

INVARIANT SUBSPACES OF NILPOTENT LINEAR OPERATORS. I.

in $\mathcal{S}(k[x]/x^6)$. It follows that $A = k[x]/x^6 \oplus k[x]/x^2 \oplus k[x]/x^6$ so the partition representing A is $(6, 6, 2)$. The submodule A' is isomorphic to $k[x]/x^5 \oplus k[x]/x^2$, the two canonical generators are mapped to $(0, 1, x)$ and $(x^4, x, 0)$ in A .

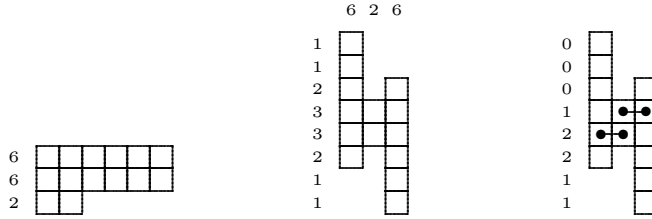

The pictures represent the Young diagram for A , the rotated Young diagram for A with the columns suitably adjusted in height and order, and the same diagram with the generators of the subgroup A' indicated. On the left hand side of the middle and the last diagram we list the entries of the dimension vector of M .

The non-stable tube

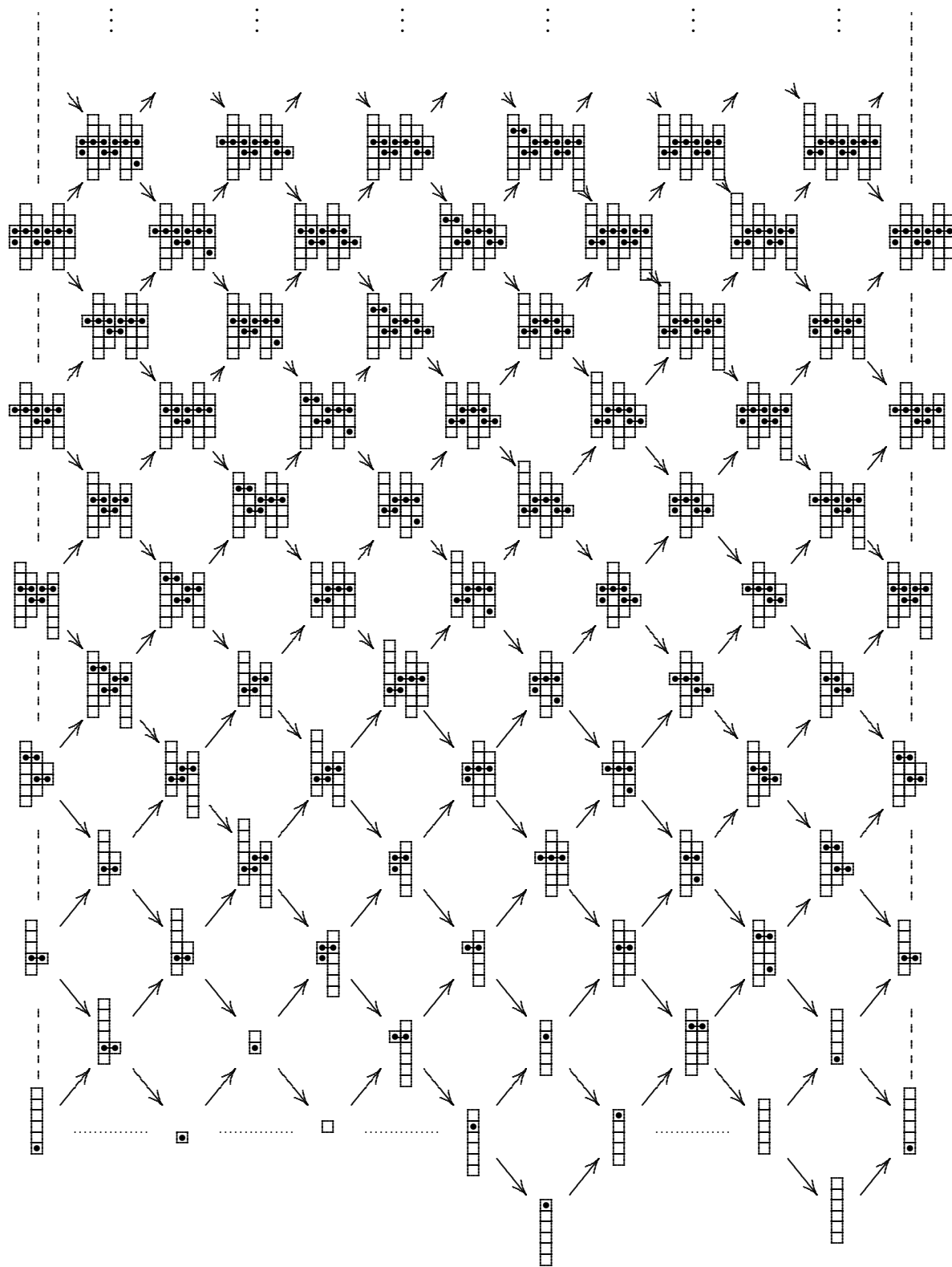

The stable non-homogeneous tubes in $\bar{\mathcal{T}}_0$

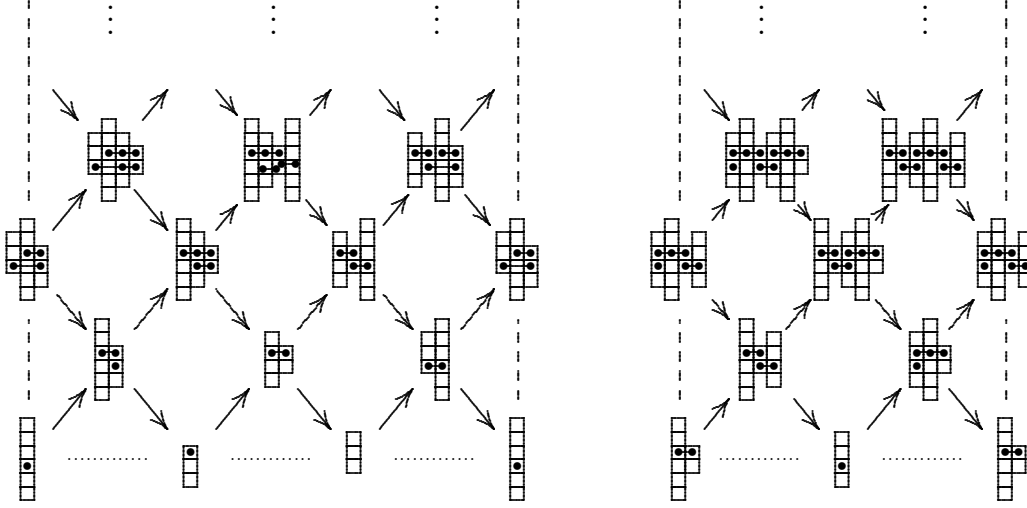

The remaining tubes in the tubular family $\bar{\mathcal{T}}_0$ are in one-to-one correspondence with the monic irreducible polynomials in $k[x]$ different from x and $x - 1$. In the case where k is an algebraically closed field, the modules on the mouth of those tubes are all as specified in Assertion (0.1.3). Here we picture the first three modules in the tube corresponding to $c \in k \setminus \{0, 1\}$. We put $c' = 1 - c$.

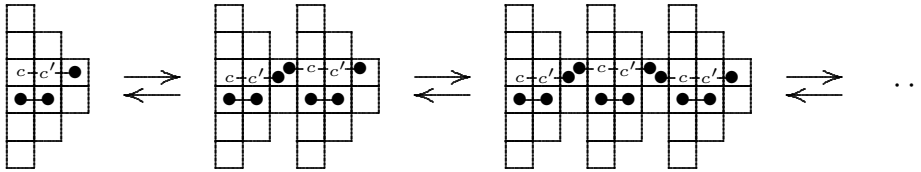

(2.4) Dimension vectors under the covering functor. In order to analyze the covering functor $\pi: \mathcal{S}(\tilde{6}) \rightarrow \mathcal{S}(6)$, we are going to look at dimension vectors. The covering functor induces a linear map from $K_0 = K_0(\text{mod } \tilde{Q})$ to $K_0(\text{mod } Q)$, which we also denote by π ; here $\pi(\mathbf{x}) = (\sum \mathbf{x}_i, \sum \mathbf{x}_{i'})$.

(2.4.1) Theorem. *Let X be an indecomposable object in $\mathcal{S}(\tilde{6})$ and put $\mathbf{x} = \mathbf{dim} X$. Then*

$$\chi(\mathbf{x}) = 0 \quad \text{if and only if} \quad \pi(\mathbf{x}) = s \cdot (12, 6) \quad \text{for some } s \in \mathbb{N}.$$

We first verify the following

Claim. *Let (V, U, T) be an indecomposable triple in $\mathcal{S}(6)$. Then the dimension pair $(v, u) = \mathbf{dim}(V, U, T)$ is in the shaded region pictured in (0.1).*

INVARIANT SUBSPACES OF NILPOTENT LINEAR OPERATORS. I.

each root corresponding to this position we label the dot by the largest entry m of the root.

Most roots (e.g. all roots where $m \geq 2$) correspond to indecomposable objects in $\mathcal{S}(\tilde{6})$ and hence via π to indecomposable triples in $\mathcal{S}(6)$. If (V, U, T) is such a triple then m is just the Krull-Remak-Schmidt multiplicity of the total space, i.e. the number of indecomposable summands of the $k[x]$ -module (V, T) .

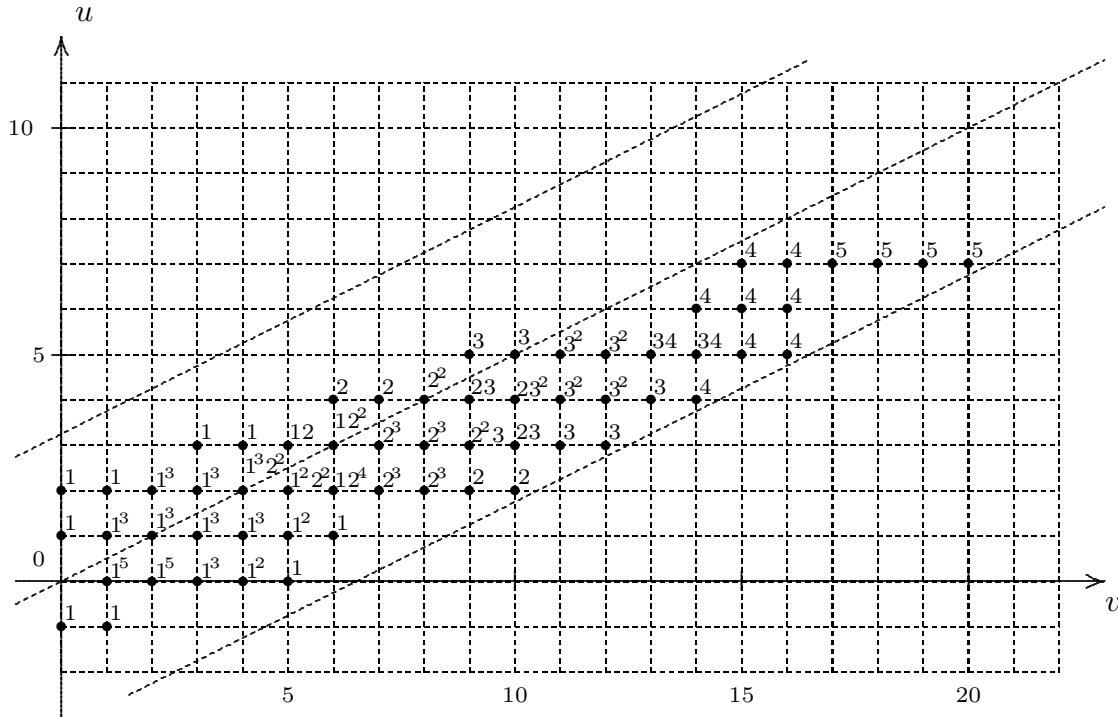

Returning to the triple $(V, U, T) = \pi(M)$ in \mathcal{D} , we need to show that

$$|\dim V - 2 \dim U| \leq 6,$$

or, equivalently,

$$\left| \sum_i \dim M_i - 2 \sum_i \dim M_{i'} \right| \leq 6.$$

Let us first consider the modules on the two rays. Given such a module, the next module on that ray is either obtained as an extension with a module on the mouth of the tube, or by applying a canonical map with kernel with dimension pair $(1, 1)$. After six such subsequent operations, the dimension pair increases by $(12, 6)$. It follows that the dimensions of all modules on both rays satisfy the above inequality.

We now deal with the remaining indecomposable objects in \mathcal{D} , which are Θ -modules.

Clearly, all roots of χ_Θ lie in the region given by $|v - 2u| \leq 6$. This finishes the proof of the claim.

INVARIANT SUBSPACES OF NILPOTENT LINEAR OPERATORS. I.

This is a tame concealed algebra with radical generator

$$\mathbf{h}^0 = \begin{matrix} 122100 \\ 123321 \end{matrix}.$$

Let M be an indecomposable Ξ -module such that the corresponding dimension pair (v, u) is labelled by the symbol \bullet in the above diagram. If M is preprojective or preinjective as a Ξ' -module then the lemma below yields a realization for each dimension pair in the orbit of (v, u) under the shift by $(12, 6)$. In case M is a regular Ξ' -module, then the tube of M contains indecomposable modules which realize each dimension pair in the orbit of (v, u) . So it remains to deal with the orbits of the pairs

$$(12, 6), (18, 6).$$

For the orbit of $(12, 6)$, take the indecomposable Ξ' -modules with dimension vector in the radical.

Finally we consider $(18, 6)$. For any $t \geq 0$, one finds an indecomposable object with dimension pair $(18, 6) + (12t, 6t)$ in the non-stable tube in \mathcal{U} . Note that these objects do not come from Ξ' -modules. For example, the unique object in the non-stable tube with dimension pair $(18, 6)$ is obtained via the covering functor from a representation with dimension vector

$$\begin{matrix} 1221000 \\ 1344321 \end{matrix}.$$

Recall that a tame concealed algebra Λ is the endomorphism ring of a preprojective tilting module over a tame hereditary algebra. An indecomposable Λ -module is said to be *homogeneous* provided it is fixed under the Auslander-Reiten translation.

(3.1.1) Lemma. *Let Λ be a tame concealed algebra and H an indecomposable homogeneous Λ -module. For M an indecomposable Λ -module in the preprojective or the preinjective component of the Auslander-Reiten quiver there is an exact sequence*

$$0 \rightarrow M \rightarrow N \rightarrow H \rightarrow 0 \quad \text{or} \quad 0 \rightarrow H \rightarrow N \rightarrow M \rightarrow 0,$$

respectively, with N indecomposable.

Proof: This is well-known for Λ being hereditary and we will use tilting theory for the general case. Consider first the case where M is in the preprojective component of the Auslander-Reiten quiver of Λ . Write Λ as the endomorphism ring of a preprojective tilting Λ' -module T , where Λ' is hereditary. Consider the torsion pair $(\mathcal{F}, \mathcal{G})$ in $\text{mod } \Lambda'$, where \mathcal{G} are the modules generated by T . Both

M and H are in the image of the tilting functor $\text{Hom}(T, -): \mathcal{G} \rightarrow \text{mod } \Lambda$, thus there are indecomposable Λ' -modules M', H' with $M = \text{Hom}(T, M')$ and $H = \text{Hom}(T, H')$, and M' is a preprojective or regular Λ' -module, whereas H' is again homogeneous. In $\text{mod } \Lambda'$, we find an exact sequence $0 \rightarrow M' \rightarrow N' \rightarrow H' \rightarrow 0$ with N' indecomposable. Take $N = \text{Hom}(T, N')$; this is an indecomposable Λ -module and under $\text{Hom}(T, -)$ we obtain an exact sequence of the form $0 \rightarrow M \rightarrow N \rightarrow H \rightarrow 0$. This completes the proof in the first case. In case M belongs to the preinjective component of $\text{mod } \Lambda$, we just use duality and obtain an exact sequence of the second kind. \checkmark

(3.2) Proof of Assertions (0.1.2) and (0.1.3). In essence, both statements are a consequence of [9], Theorem 5.2.6, which states that the category of modules over a tubular algebra Θ is controlled by the associated integral quadratic form χ_Θ .

Let M be an indecomposable Θ -module where Θ is the tubular algebra from Section 1. By [9], Theorem 5.2.6, the dimension vector \mathbf{d} of M is either a root or a radical vector for χ_Θ . In the first case M is determined uniquely, up to isomorphism, by \mathbf{d} and conversely, every vector \mathbf{d} which is a root of χ_Θ can be realized by an indecomposable module. If \mathbf{d} is a radical vector for χ_Θ then there are infinitely many isomorphism classes of indecomposable modules of dimension vector \mathbf{d} provided only that the underlying base field k has infinite cardinality.

Let us deal with radical vectors first. According to [9], Theorem 5.1.3(c), the radical vectors corresponding to index γ form a free abelian group of rank 1 containing

$$\mathbf{r}_\gamma = q \cdot \mathbf{h}^0 + p \cdot \mathbf{h}^\infty$$

where $\gamma = \frac{p}{q}$ with p and q non-negative integers which are relatively prime. It follows that \mathbf{r}_γ is a generator of this group. Suppose that k is a field of infinite cardinality, $\gamma = \frac{p}{q} \in \mathbb{Q}_0^+$ as above, and $m \in \mathbb{N}$. Then there are infinitely many indecomposable objects, up to isomorphism, of dimension vector $m\mathbf{r}_\gamma$ in $\mathcal{T}'_0 \sqcup \mathcal{T}$. Under the covering functor, they correspond to an infinite family of pairwise non-isomorphic objects with dimension pair $m(p+q) \cdot (12, 6)$ in $\bar{\mathcal{T}}_\gamma$. In particular if $\gamma = 0$, then for each $m \in \mathbb{N}$ and $c \in k \setminus \{0, 1\}$ we have pictured at the end of (2.3) an indecomposable module with dimension pair $m \cdot (12, 6)$ which occurs in the homogeneous tube in $\bar{\mathcal{T}}_0$ corresponding to the monic irreducible polynomial $x - c$.

Now suppose that a dimension pair (v, u) is given which is not an integer multiple of $(12, 6)$. We show that there are only finitely many indecomposable subspace configurations with this dimension pair, up to isomorphism, and that this number $n(v, u)$ does not depend on the choice of the base field k .

Let $n'(v, u)$ be the number of roots of χ_Θ for which the corresponding index γ is in \mathbb{Q}^+ . (Clearly, this number is finite since up to the shift, there are only finitely many connected dimension vectors which are mapped under π to (v, u) .) This is the number of indecomposable objects in $\mathcal{T} = \bigsqcup_{\gamma \in \mathbb{Q}^+} \mathcal{T}_\gamma$ which under the covering

functor correspond to an indecomposable subspace configuration with dimension pair (v, u) . There may be further subspace configurations of this dimension, but they must correspond to objects in the tubular family $\bar{\mathcal{T}}_0$, and hence occur in one of the three non-homogeneous tubes which we have pictured in (2.3). Say there are $n_0(v, u)$ such objects; again, this number does not depend on the choice of the base field k because the operations which we performed on the tubular family \mathcal{T}'_∞ work for every base field, and the number is finite because within each tube the dimensions tend to infinity with increasing distance to the mouth. Then we can compute $n(v, u)$ as the sum $n'(v, u) + n_0(v, u)$. We have seen that this number is finite and independent of k .

(3.3) Proof of Assertion (0.1.4). We start with the following observation. Let $\gamma = \frac{p}{q} \in \mathbb{Q}_0^+$ be written in lowest terms. The modules on the mouth of the homogeneous tubes in \mathcal{T}_γ , and some modules in the non-homogeneous tubes, form a one-parameter family of indecomposables of dimension vector $q\mathbf{h}^0 + p\mathbf{h}^\infty$. Moreover, the remaining modules with this dimension vector in \mathcal{T}_γ are in the non-homogeneous tubes; there are $6 + 3 + 2$ of them if $\gamma \neq 0$ and $4 + 3 + 2$ if $\gamma = 0$. Under the covering functor, the family in \mathcal{T}_γ corresponds to a family in $\bar{\mathcal{T}}_\gamma$ with dimension pair $(p + q) \cdot (12, 6)$. Similarly for $s > 0$, the s -fold selfextension of each of these modules is an object with dimension vector

$$s(q\mathbf{h}^0 + p\mathbf{h}^\infty)$$

in \mathcal{T}_γ . Those modules give rise to a family of indecomposables with dimension pair $s(p + q) \cdot (12, 6)$.

Thus given $t > 0$, any $p \in \{0, 1, \dots, t - 1\}$ gives rise to a family of indecomposables with dimension pair $t \cdot (12, 6)$: Put $\gamma = \frac{p}{t-p}$ and let s be the greatest common divisor of p and $t - p$. Then there is a one-parameter family in $\bar{\mathcal{T}}_\gamma$ containing the s -fold selfextensions of the modules on the mouths of the homogeneous tubes.

It remains to show that there are only finitely many indecomposables with dimension pair $t \cdot (12, 6)$ which are not in one of the families. In fact, we can describe the possible exceptions: If $\gamma = \frac{p}{t-p}$ as above, then for each family in \mathcal{T}_γ , there are at most $6 + 3 + 2$ (or $4 + 3 + 2$ if $\gamma = 0$) indecomposables in the non-homogeneous tubes in \mathcal{T}_γ which are not in the family, their distance from the mouth is the product of the rank with the greatest common divisor of p and $t - p$.

Suppose a module \bar{M} in one of the non-homogeneous tubes has distance from the mouth which is not a multiple of the rank of the tube. Then there is a corresponding module $M \in \mathcal{D}$ such that $\pi(M) = \bar{M}$; this module M occurs in a non-homogeneous tube of the same rank and has the same distance from the mouth of its tube. Then either M is a Θ -module and $\mathbf{dim} M$ is a root of the quadratic form for Θ or M is in one of the inserted rays. We have seen in the proof of Assertion (0.1.1) that in neither of the two cases the dimension pair of \bar{M} is a multiple of $(12, 6)$.

(3.4) Proof of Assertions (0.1.5) and (0.1.6). As in the case of tubular algebras one observes that the infinite radical $\tilde{\mathcal{I}}$ of $\mathcal{S}(\tilde{6})$ is the following ideal: Let M belong to \mathcal{T}_γ and M' to $\mathcal{T}_{\gamma'}$, then

$$\tilde{\mathcal{I}}(M, M') = \begin{cases} 0 & \text{if } \gamma \geq \gamma' \\ \text{Hom}(M, M') & \text{if } \gamma < \gamma' \end{cases}.$$

Also, the ideal $\tilde{\mathcal{I}}$ is idempotent. Namely, consider a map $f: M \rightarrow M'$ where $\gamma < \gamma'$, and choose some rational number γ'' with $\gamma < \gamma'' < \gamma'$. One knows that $\mathcal{T}_{\gamma''}$ is a separating tubular family, thus there is a module M'' in $\mathcal{T}_{\gamma''}$ such that f factors through M'' , say $f = f_2 f_1$ with $f_1: M \rightarrow M''$ and $f_2: M'' \rightarrow M'$. Since both f_1 and f_2 belong to $\tilde{\mathcal{I}}$, we see that f belongs to $\tilde{\mathcal{I}}^2$.

Under the covering functor $\pi: \mathcal{S}(\tilde{6}) \rightarrow \mathcal{S}(6)$, the infinite radical $\tilde{\mathcal{I}}$ of $\mathcal{S}(\tilde{6})$ is mapped onto the infinite radical \mathcal{I} of $\mathcal{S}(6)$. Since $\tilde{\mathcal{I}}$ is idempotent, also \mathcal{I} is idempotent.

Let X be an indecomposable object of $\mathcal{S}(6)$. Choose an indecomposable object M of $\mathcal{S}(\tilde{6})$ with $\pi(M) = X$. The covering property of π asserts that one can identify $\text{End}(X) = \text{Hom}(X, X)$ under π with the graded ring

$$\Pi = \bigoplus_{i \in \mathbb{Z}} \Pi_i, \text{ where } \Pi_i = \text{Hom}(M, M[i]).$$

Here, the product of $f \in \text{Hom}(M, M[i])$ and $g \in \text{Hom}(M, M[j])$ is $f[j] \circ g \in \text{Hom}(M, M[i+j])$. As we know, $\text{Hom}(M, M[i]) = 0$ for $i < 0$, thus $\Pi = \bigoplus_{i \in \mathbb{N}_0} \Pi_i$. Also, $\text{Hom}(M, M[i]) = 0$ for $i \geq 8$, since we can assume that the support of the total space of M is contained in $[0, 7]$. This shows that the ideal $\Pi_+ = \bigoplus_{i > 0} \Pi_i$ of Π is nilpotent with nilpotency index at most 8. However under the identification of Π and $\text{End}(X)$, the ideal Π_+ corresponds to $I = \mathcal{I}(X, X)$. Also, under this identification, $\Pi/\Pi_+ = \text{End}(M)$ is isomorphic to $\text{End}(X)/I$. But $\text{End}(M)$ is a local uniserial ring for any indecomposable object in $\mathcal{S}(\tilde{n})$. This completes the proof.

Note that for most of the indecomposable objects X in $\mathcal{S}(6)$ we even must have $\mathcal{I}(X, X)^7 = 0$, since usually the support of the total space is M is of length at most 7, so that Π_+ has nilpotency index at most 7. The only indecomposable objects M in $\mathcal{S}(\tilde{6})$ such that the total space of M has support of length 8 have been exhibited in Section (2.3).

Let us present here an object $X \in \mathcal{S}(6)$ and a non-zero endomorphism

$$\varepsilon \in \mathcal{I}(X, X)^7.$$

Let M in $\mathcal{S}(\tilde{6})$ be the object in the non-stable tube in \mathcal{D} at the second intersection of the ray starting at $P(7)$ and the coray ending at $P(5')$. Then $X = (A, A') =$

INVARIANT SUBSPACES OF NILPOTENT LINEAR OPERATORS. I.

$\pi(M)$ can be pictured as follows. (The shaded box will be explained below.)

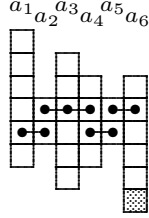

Write $A = k[x]/x^6 \oplus k[x]/x^2 \oplus k[x]/x^6 \oplus k[x]/x^4 \oplus k[x]/x^2 \oplus k[x]/x^6$ and denote by a_i a generator of the i -th summand. Then A' is generated by $a_1x^4 + a_2x$, $a_2 + a_3x^2 + a_4x$, $a_4x^2 + a_5x$, and $a_5 + a_6x$. Define $\varphi : A \rightarrow A$ by putting $\varphi(a_1) = a_3$, $\varphi(a_2) = a_4x^2$, $\varphi(a_3) = a_6$ and $\varphi(a_i) = 0$ for $i \geq 4$, this defines an endomorphism of (A, A') . Note that φ^2 is the map given by $\varphi^2(a_1) = a_6$ and $\varphi^2(a_i) = 0$ for $i \geq 2$. In fact, $\varphi = \pi(f)$ for a map $f : M \rightarrow M[1]$, so φ is in the infinite radical. Let $T \in \text{End}(A, A')$ be given by multiplication by x , so T is in the infinite radical, too. Then the composition

$$\varepsilon = T^5 \circ \varphi^2 \in \mathcal{I}(X, X)^7$$

is non-zero, more precisely, the image of ε is just ka_6x^5 , pictured as the shaded box in the above diagram.

(3.5) Proof of Assertion (0.1.7). Let X be an indecomposable object in $\mathcal{S}(6)$ with dimension pair (v, u) . First, assume that (v, u) is an integral multiple of $(12, 6)$. Let M be an indecomposable object in $\mathcal{S}(\tilde{6})$ with $\pi(M) = X$. Theorem (2.4.1) asserts $\chi(\mathbf{dim} M) = 0$. But then there is an increasing chain of inclusions

$$0 = N_0 \subset N_1 \subset \cdots \subset N_m \subset \cdots$$

of indecomposable objects in $\mathcal{S}(\tilde{6})$ such that N_i/N_{i-1} is isomorphic to M for all $i \geq 1$. Using the covering functor π we obtain indecomposable objects $Y_i = \pi(N_i)$ in $\mathcal{S}(6)$. Since π is exact, it follows that Y_i/Y_{i-1} is isomorphic to X for all $i \geq 1$.

Next we deal with the case where (v, u) is not a multiple of $(2, 1)$. Assume there is a chain of inflations

$$0 = Y_0 \subset Y_1 \subset \cdots \subset Y_m$$

with Y_i/Y_{i-1} isomorphic to X for all $1 \leq i \leq m$. The dimension pair of Y_m is (mv, mu) and

$$|mv - 2mvu| = m|v - 2u| \geq m,$$

since $v - 2u$ is non-zero. According to Assertion (0.1.1), we see that $m \leq 6$.

We have mentioned in (0.1) that one may expect that an indecomposable object in $\mathcal{S}(6)$ with dimension pair not an integral multiple of $(12, 6)$ can be

m -stackable only for $m \leq 6$. If one tries to prove this assertion, one has to be aware that when dealing with a covering functor, usually new exact sequences are created: In general, monomorphisms cannot be lifted to monomorphisms.

4. A Sort of Double Covering for $\mathcal{S}(6)$

In Section 1, all stable tubes in the fundamental domain of the category $\mathcal{S}(\tilde{6})$ have been obtained as tubes of regular modules over the tubular algebra Θ . In this section we exhibit a slightly more complicated finite dimensional algebra Ω which provides a corresponding model for two adjacent fundamental domains of $\mathcal{S}(\tilde{6})$. Thus the regular Ω -modules form a sort of double covering for $\mathcal{S}(6)$.

(4.1) The algebra Ω . Here is the algebra Ω , given by the following quiver with relations

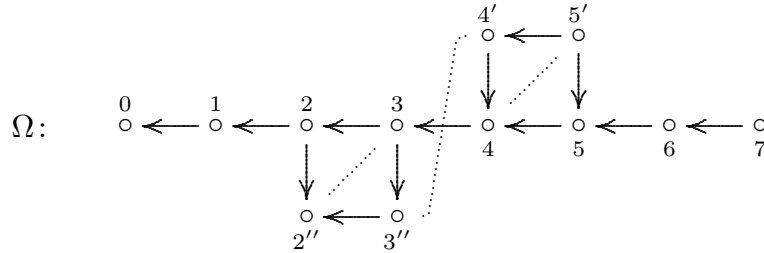

such that in addition any composition of six of the horizontal maps in the middle is zero. In case we need a notation for the arrows, we will use the following notation:

- the horizontal arrows $i-1 \leftarrow i$ will be denoted by p_i or just p ,
- the horizontal arrow $4' \leftarrow 5'$ by p'_5 ,
- the horizontal arrow $2'' \leftarrow 3''$ by p''_3 .
- the vertical arrows $i \leftarrow i'$ will be denoted by μ_i .
- the vertical arrows $i'' \leftarrow i$ will be denoted by ε_i .

In order to see the relationship to $\mathcal{S}(\tilde{6})$ one has to deal with the kernels

$$V'_2 = \text{Ker } \varepsilon_2 \quad \text{and} \quad V'_3 = \text{Ker } \varepsilon_3.$$

of the two lower vertical maps ε_i ; thus a representation V of Ω with both μ_4 and μ_5 injective yields the corresponding object $E(V)$ in $\mathcal{S}(\tilde{6})$.

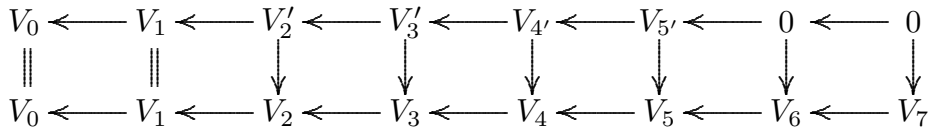

(4.2) The structure of the category of Ω -modules. Consider the following three subquivers which yield algebras $\Omega_0, \Omega_1, \Omega_2$ that are tame concealed of

INVARIANT SUBSPACES OF NILPOTENT LINEAR OPERATORS. I.

type \tilde{E}_7 :

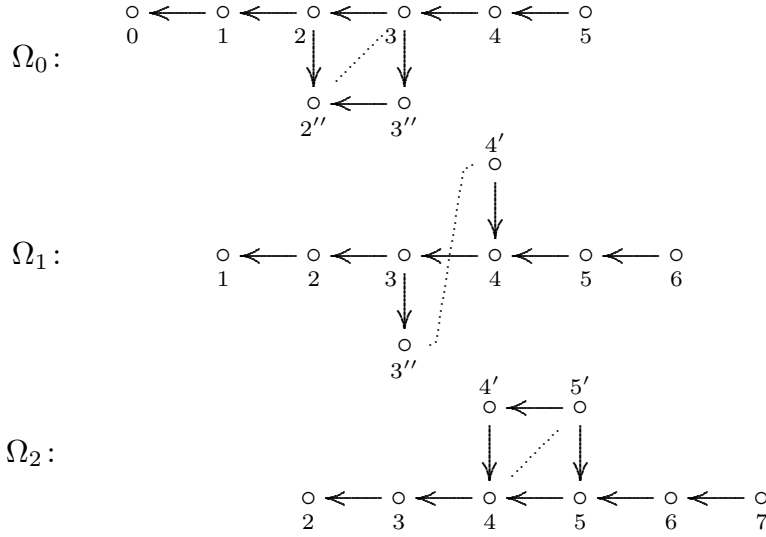

The preprojective component of Ω_0 is a component of Ω :

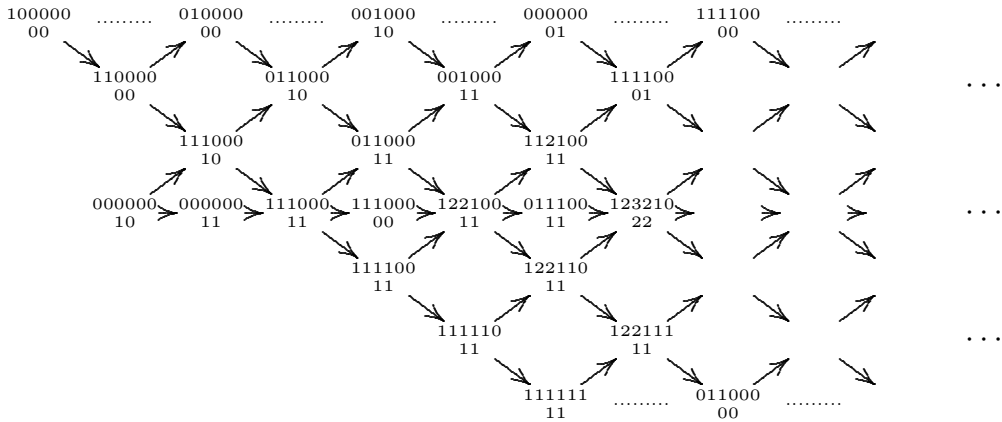

The radicals of the projective modules $P(6)$ and $P(4')$ belong to the mouth of the 4-tube of Ω_0 , here is the corresponding component:

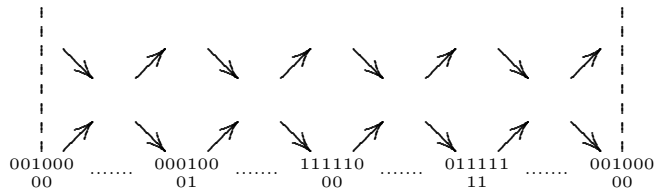

If we insert the rays starting at $P(4')$ and $P(6)$, we obtain the following tube:

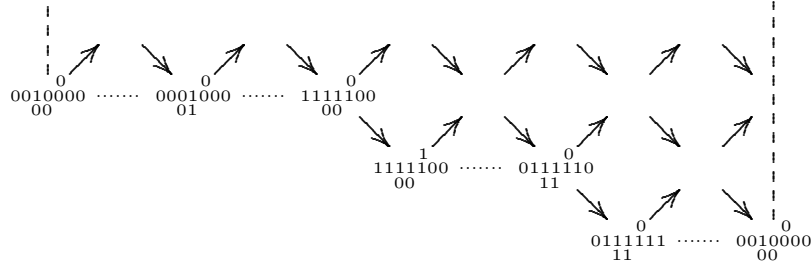

It follows that the union of Ω_0 and Ω_1 is a tubular algebra of tubular type $(6, 3, 2)$. By duality, the union of Ω_1 and Ω_2 is also a tubular algebra of tubular type $(6, 3, 2)$.

The 4-tube of Ω_1 is contained in the following 6-tube of Ω , the coray-inserciones for adding the vertices 0 and $2''$ and the ray inserciones for adding the vertices 7 and $5'$ yield two projective-injective modules:

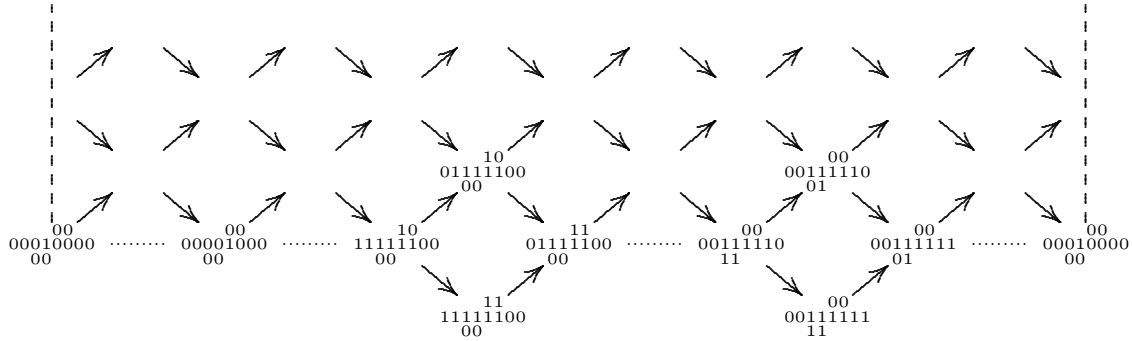

In conclusion, the category $\text{mod } \Omega$ has the following shape. Note that the indecomposable regular Ω_i -modules are contained in the tubular families labelled \mathcal{T}_i for $i = 0, 1, 2$.

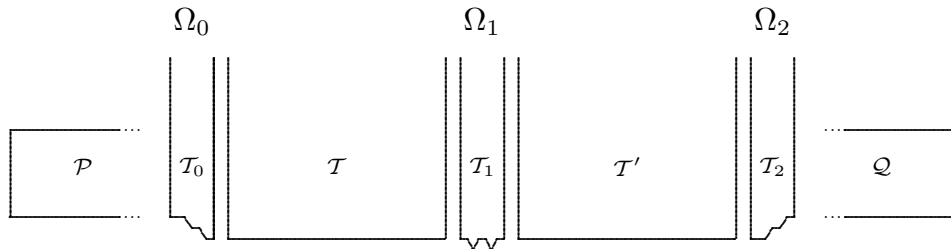

(4.3) The representation embedding into $\mathcal{S}(\tilde{6})$. Let us call an indecomposable Ω -module *regular* provided none of its summands occurs in one of the components \mathcal{P} or \mathcal{Q} . Then the correspondence $V \mapsto E(V)$ from the introduction to this section gives rise to a representation embedding from the regular Ω -modules into $\mathcal{S}(\tilde{6})$. For this we show that every regular representation has the property that the

INVARIANT SUBSPACES OF NILPOTENT LINEAR OPERATORS. I.

maps ε_2 and ε_3 are epimorphisms and the maps μ_4 and μ_5 are monomorphisms. Clearly, for a representation $M \in \text{mod } \Omega$ the following conditions are equivalent.

$$\begin{array}{ll}
 \varepsilon_2 \text{ surjective} & \text{iff} \quad \text{Hom}(M, \underset{11}{\overset{00}{00000000}}) = 0 \\
 \varepsilon_3 \text{ surjective} & \text{Hom}(M, S(3'')) = 0 \\
 \mu_4 \text{ injective} & \text{Hom}(S(4'), M) = 0 \\
 \mu_5 \text{ injective} & \text{Hom}(\underset{00}{\overset{11}{00000000}}, M) = 0
 \end{array}$$

We have already seen that the modules $S(3'')$ and $\underset{11}{\overset{00}{00000000}}$ occur in the component \mathcal{P} , and dually, the modules $S(4')$ and $\underset{00}{\overset{11}{00000000}}$ are both in \mathcal{Q} .

Thus, the regular Ω -modules are embedded in $\mathcal{S}(\tilde{6})$ as follows: The tubular families \mathcal{T}_0 and \mathcal{T}_2 in $\Omega\text{-mod}$ are contained in the subcategories $\mathcal{U}[-1]$ and $\mathcal{U}[1]$ of $\mathcal{S}(\tilde{6})$, and there are equivalences between each of the three full subcategories \mathcal{T} , \mathcal{T}_1 , and \mathcal{T}' of $\Omega\text{-mod}$ and the corresponding subcategories \mathcal{T} , \mathcal{U} , and $\mathcal{T}[1]$ of $\mathcal{S}(\tilde{6})$:

The regular Ω_0 -modules correspond to the regular Θ_0 -modules (see Section 1) by taking cokernels; and hence, via the representation embedding E , they give rise to all the indecomposable modules in the tubes in $\mathcal{U}[-1]$ in $\mathcal{S}(\tilde{6})$, with the exception of several modules on two rays and two corays in the tube of rank 6. Thus \mathcal{T}_0 , being obtained from the tubular family in $\Omega_0\text{-mod}$ by a twofold ray insertion, is a full subcategory of $\mathcal{U}[-1]$ in $\mathcal{S}(\tilde{6})$, and dually, the tubular family \mathcal{T}_2 of $\Omega\text{-mod}$ becomes a full subcategory of $\mathcal{U}[1]$. On the categories \mathcal{T} , \mathcal{T}_1 and \mathcal{T}' , the representation embedding E induces an equivalence. To verify density it suffices to note that the support of objects in $\mathcal{T} \sqcup \mathcal{U} \sqcup \mathcal{T}[1]$ coincides with the support of Ω since the injective $I(-1) = P(4')$ lies in $\mathcal{U}[-1]$ in $\mathcal{S}(\tilde{6})$ and the projectives $P(6')$ and $P(8)$ are in $\mathcal{U}[1]$; moreover, each object M in $\mathcal{T} \sqcup \mathcal{U} \sqcup \mathcal{T}[1]$ has the property that the maps μ_0 and μ_1 are isomorphisms, this follows from the injective modules $I(0)' = P(5)$ and $I(1)' = P(6)$ being contained in $\mathcal{U}[-2]$ and $\mathcal{U}[-1]$ in $\mathcal{S}(\tilde{6})$, respectively.

Combining the embedding of the regular Ω -modules in $\mathcal{S}(\tilde{6})$ with the covering functor $\pi: \mathcal{S}(\tilde{6}) \rightarrow \mathcal{S}(6)$ we obtain the double covering mentioned in the introduction.

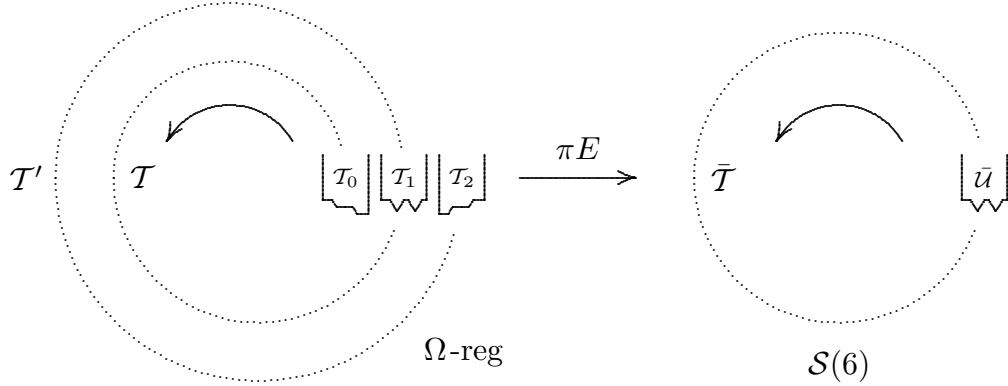

Part B. Operators with nilpotency index different from 6.

5. General considerations.

(5.1) The boundary modules. We will extract a lot of information about the shape of the submodule category $\mathcal{S}(n)$ from our study of the *boundary modules*: They form the $\tau_{\mathcal{S}}$ -orbit to which the two projective-injective objects are attached. In this section, let Λ be a commutative uniserial ring. We consider the two projective objects in $\mathcal{S}(\Lambda)$, P and P' , their radicals $R = \text{rad } P$ and $R' = \text{rad } P'$, the end terms of their source maps J and P'/K , and the simple and the quasi-simple representations S and K .

$$\begin{array}{ll}
 P &= (\Lambda, 0) & P' &= (\Lambda, \Lambda) \\
 R &= (\text{rad } \Lambda, 0) & R' &= (\Lambda, \text{rad } \Lambda) \\
 J &= (\Lambda, \text{soc } \Lambda) & P'/K &= (\Lambda/\text{soc } \Lambda, \Lambda/\text{soc } \Lambda) \\
 S &= (\text{soc } \Lambda, 0) & K &= (\text{soc } \Lambda, \text{soc } \Lambda)
 \end{array}$$

Note that in case $n = 2$, there are three pairs of isomorphic representations in $\mathcal{S}(\Lambda)$; otherwise for $n > 2$, all the above representations are pairwise non-isomorphic. Using arguments from [11] we show that these modules form a part of a component of the Auslander-Reiten quiver for $\mathcal{S}(\Lambda)$ of the following shape.

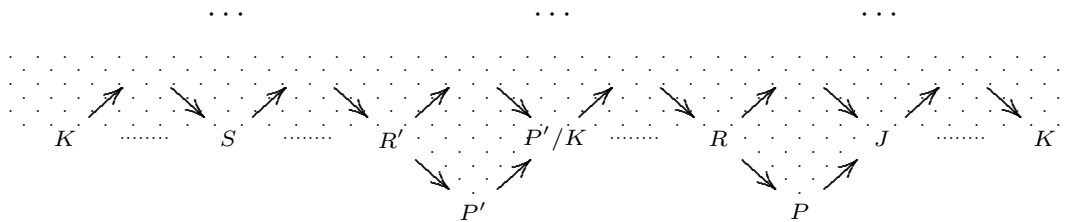

Clearly, the inclusions of the radicals $R' \rightarrow P'$ and $R \rightarrow P$ are sink maps in $\mathcal{S}(\Lambda)$; and according to Lemma (1.3.1), the maps $\text{incl}: P \rightarrow J$ and $\text{can}: P' \rightarrow P'/K$

INVARIANT SUBSPACES OF NILPOTENT LINEAR OPERATORS. I.

are source maps. In order to verify that the non-projective modules form an orbit under the Auslander-Reiten translation $\tau_{\mathcal{S}}$ we recall from [11], Theorem 5.1, the formula for the translate of an indecomposable non-projective object $c \in \mathcal{S}(\Lambda)$:

$$\tau_{\mathcal{S}}(c) = \text{Mimo } \tau_{\Lambda} \text{ Cok}(c)$$

We explain the three steps used for the computation of $\tau_{\mathcal{S}}(c)$. For this, we display objects in $\mathcal{S}(\Lambda)$ as maps between Λ -modules, so c is given by an inclusion map $(c: C' \rightarrow C)$. Let $(c'': C \rightarrow C'')$ be the cokernel of c , then the Auslander-Reiten translate in the category $\text{mod } \Lambda$ gives rise to a morphism $\tau_{\Lambda}(c'')$ in the category $\underline{\text{mod}} \Lambda$ which we represent by a map $(\tilde{a}: A' \rightarrow \tilde{A})$ in the full subcategory $\text{mod}' \Lambda$ of all Λ -modules which have no non-zero injective direct summand; this map \tilde{a} is determined uniquely, up to a morphism which factors through an injective module. From this we obtain $\tau_{\mathcal{S}}(c)$ by making \tilde{a} a “minimal monomorphism”:

$$\text{Mimo}(\tilde{a}) = [\tilde{a} \ e]: A' \rightarrow \tilde{A} \oplus \text{I}(\text{Ker } \tilde{a})$$

where e is an extension of the inclusion map $\text{Ker } \tilde{a} \rightarrow \text{I}(\text{Ker } \tilde{a})$ to A' . According to [11], Proposition 4.1, the isomorphism class of $\text{Mimo}(\tilde{a})$ in $\mathcal{S}(n)$ does not depend on the choice for \tilde{a} nor on the choice for e .

For example, consider the case that $c = K = (1_k: k \rightarrow k)$ where $k = \text{soc } \Lambda$. Then \tilde{a} is just the cokernel map $(0: k \rightarrow 0)$, and making this map a monomorphism yields $\text{Mimo}(k \rightarrow 0) = (\text{incl}: k \rightarrow \Lambda)$, so the translate is given by: $\tau_{\mathcal{S}}(K) = J$. Similarly,

$$\tau_{\mathcal{S}}(J) = \text{Mimo}(\tau_{\Lambda}(\Lambda \rightarrow \Lambda/k)) = \text{Mimo}(0 \rightarrow \Lambda/k) = (0 \rightarrow \Lambda/k) = R \quad \text{etc.}$$

In the situation where $\Lambda = k[x]/x^n$, the boundary modules in $\mathcal{S}(n)$ occur in the image of the covering functor $\pi|_{\mathcal{S}}: \mathcal{S}(\tilde{n}) \rightarrow \mathcal{S}(n)$. Thus, for each boundary module $\bar{B} \in \mathcal{S}(n)$ there is an orbit under the shift of boundary modules $B[i]$, $i \in \mathbb{Z}$, in the category $\mathcal{S}(\tilde{n})$. We index the boundary modules such that $i = \max\{j \in \mathbb{Z} : B[i]_j \neq 0\}$ holds. We obtain the following (part of an) orbit of boundary modules in $\mathcal{S}(\tilde{n})$.

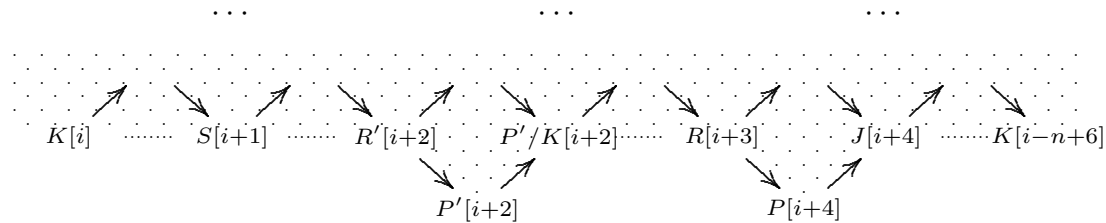

Thus, the boundary modules in $\mathcal{S}(\tilde{n})$ exhibit a shift $M \mapsto M[n - 6]$ given by the sixfold application of $\tau_{\mathcal{S}}$; we will see how this shift characterizes the shape of the Auslander-Reiten quiver of the category $\mathcal{S}(n)$, and how it contributes to the number of indecomposable objects.

(5.2) The stable part. Frequently we will use [7], Theorem 2: A connected component \mathcal{C} of the Auslander-Reiten quiver Γ which contains a τ -periodic module has stable part of the form $\mathbb{Z}\Delta/\varphi$ where Δ is a Dynkin diagram or A_∞ and φ is an admissible automorphism of $\mathbb{Z}\Delta$. This result applies in particular to each of the categories $\mathcal{S}(n)$ since here every module has $\tau_{\mathcal{S}}$ -period a divisor of 6 ([11], Corollary 6.5).

6. Submodule Categories of Finite Representation Type

For each $n \leq 5$, the category $\mathcal{S}(n)$ is of finite representation type as we will see. In each case, we present the Auslander-Reiten quiver and display every one of the indecomposable modules. It turns out that the number $s(n)$ of indecomposable objects in $\mathcal{S}(n)$, up to isomorphism, is given by the formula

$$s(n) = 2 + 2(n - 1) \frac{6}{6 - n}$$

which we will discuss in (6.6).

(6.1) The case $n = 1$. The category $\mathcal{S}(1)$ is semisimple, the only indecomposable triples are $(k, 0, 0)$ and $(k, k, 1_k)$.

(6.2) The case $n = 2$. In the category $\mathcal{S}(2)$, among the eight boundary modules there are the two projective-injective representations and in addition three pairs of isomorphic representations. If X is a non-projective boundary module in $\mathcal{S}(\tilde{2})$ then the isomorphism $\tau_{\mathcal{S}}^3 X \cong X[-2]$ implies that there are two $\tau_{\mathcal{S}}$ -orbits of stable boundary modules in $\mathcal{S}(\tilde{2})$, one containing X , the other one containing $X[1]$. These two orbits are connected as for example the Auslander-Reiten sequence ending at K demonstrates, and together with the projective-injective modules form the following component of the Auslander-Reiten quiver of $\mathcal{S}(\tilde{2})$:

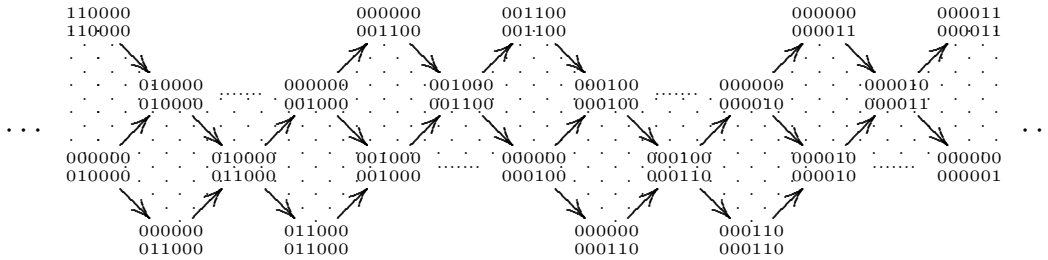

Thus, all indecomposables in $\mathcal{S}(\tilde{2})$ are boundary modules. The Auslander-Reiten quiver for $\mathcal{S}(2)$ is as follows. Here and for the following representation finite categories we use two presentations for the objects in the Auslander-Reiten quiver: First, we represent each module by the dimension vector of a corresponding object

INVARIANT SUBSPACES OF NILPOTENT LINEAR OPERATORS. I.

in $\mathcal{S}(\tilde{n})$ and second, we display the embedding of the submodule by using box notation as introduced in (2.3).

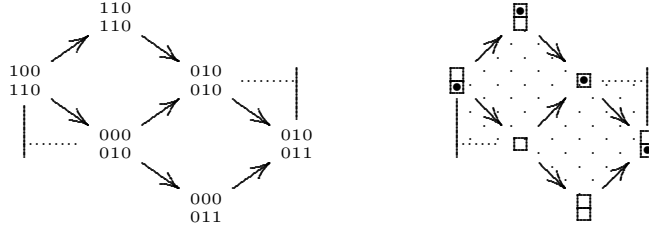

For each of the categories $\mathcal{S}(n)$ where $2 \leq n \leq 5$ we picture the distribution of the possible dimension pairs $(v, u) = \mathbf{dim}(V, U, T)$ for the indecomposable triples (V, U, T) . We label each point (v, u) with the Krull-Remak-Schmidt multiplicity (which is the number of indecomposable direct summands) of the $k[x]$ -module given by (V, T) . Note that in each case the dimension pairs lie in the stripe bounded by the lines $u = \frac{1}{2}v \pm \frac{1}{2}n$. Here is the distribution for $n = 2$:

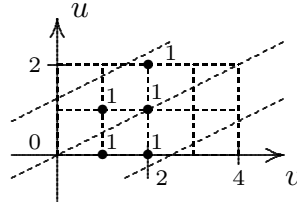

(6.3) The case $n = 3$. We derive the shape of the Auslander-Reiten quiver for $\mathcal{S}(3)$ from our knowledge about the boundary modules. Since the boundary modules are pairwise non-isomorphic, the formula $\tau_{\mathcal{S}}^6 X \cong X[-3]$ for a non-projective boundary module X in the covering category $\mathcal{S}(\tilde{3})$ implies that there are 3 orbits of boundary modules in the stable part $\mathbb{Z}\Delta$ of $\mathcal{S}(\tilde{3})$, more precisely, the orbits containing X , $X[1]$ and $X[2]$, are pairwise disjoint. The automorphism of $\mathbb{Z}\Delta$ given by $M \mapsto M[1]$ permutes these three orbits and hence gives rise to an automorphism ρ of the Dynkin diagram Δ of order three. The only Dynkin diagram Δ admitting such an automorphism is $\Delta = D_4$. Thus, the shape of the stable part of $\Gamma(3)$ is determined as $\mathbb{Z}D_4/\tau_{\mathcal{S}}^2\rho$. Here is the Auslander-Reiten quiver:

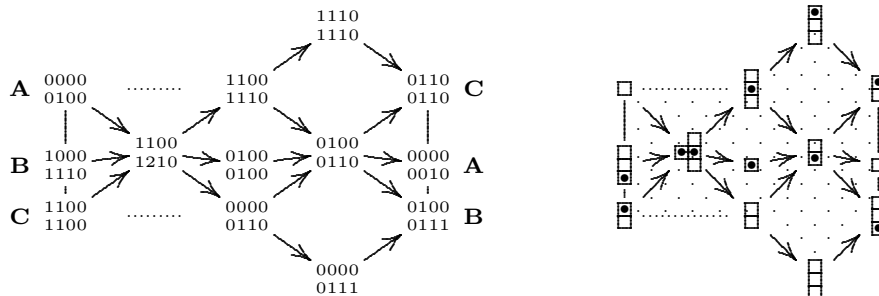

We conclude this section with the distribution of the dimension pairs of the

indecomposable triples in the category $\mathcal{S}(3)$.

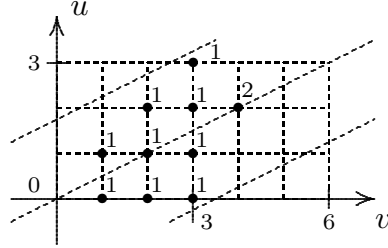

(6.4) The case $n = 4$. Here again the boundary modules are pairwise non-isomorphic, and the formula $\tau_S^6 X \cong X[-2]$ for a non-projective module in the covering category $\mathcal{S}(\tilde{4})$ yields two orbits of boundary modules in the Auslander-Reiten quiver for $\mathcal{S}(\tilde{4})$. The automorphism on the stable part $\mathbb{Z}\Delta$ of this Auslander-Reiten quiver given by the shift $M \mapsto M[1]$ permutes these two orbits and induces a non-trivial action σ of order two on the Dynkin diagram Δ . Hence, Δ is of type A_n , D_n , or E_6 . First we compute the dimension vectors of the indecomposables in the Auslander-Reiten sequences containing a boundary module.

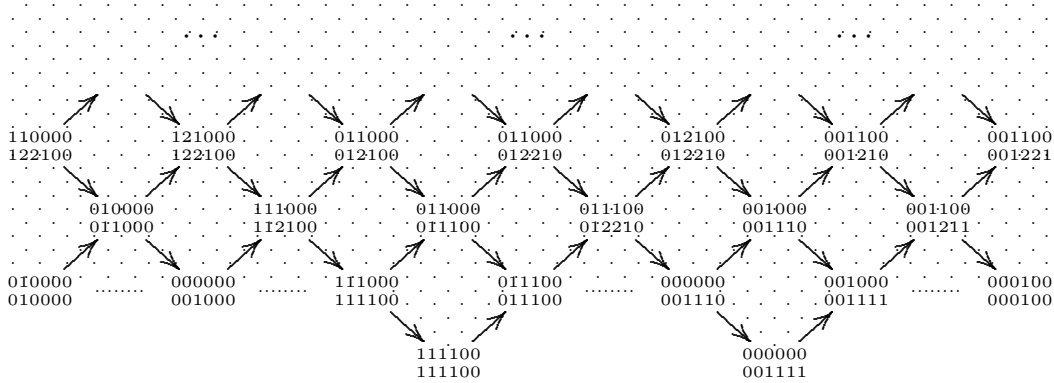

The dimension vectors in the τ_S -orbit next to the boundary modules correspond to indecomposables (since at least the first one does); they have period six, up to the shift. This excludes the case that Δ has type D_n for some n , as the shift $M \mapsto M[1]$ maps the central axis of the diagram $\mathbb{Z}D_n$ onto itself. Hence, the modules in the second orbit next to the boundary modules must be indecomposable. They occur with period three, up to the shift, so either $\Delta = A_5$ or $\Delta = E_6$ holds. For dimension reasons, the case $\Delta = A_5$ is not possible: The Auslander-Reiten sequence starting at $\begin{smallmatrix} 1100 \\ 1221 \end{smallmatrix}$ would have to have a middle term which is the direct sum of the extension of $\begin{smallmatrix} 01 \\ 01 \end{smallmatrix}$ and $\begin{smallmatrix} 000 \\ 001 \end{smallmatrix}$ and the extension of $\begin{smallmatrix} 111 \\ 111 \end{smallmatrix}$ and $\begin{smallmatrix} 0000 \\ 0111 \end{smallmatrix}$; but clearly, there is no exact sequence $0 \rightarrow \begin{smallmatrix} 1100 \\ 1221 \end{smallmatrix} \rightarrow \begin{smallmatrix} 010 \\ 011 \end{smallmatrix} \oplus \begin{smallmatrix} 1110 \\ 1221 \end{smallmatrix} \rightarrow \begin{smallmatrix} 1210 \\ 1221 \end{smallmatrix} \rightarrow 0$, a contradiction. Hence,

INVARIANT SUBSPACES OF NILPOTENT LINEAR OPERATORS. I.

$\Delta = E_6$ and the Auslander-Reiten quiver for $\mathcal{S}(4)$ has stable part $\mathbb{Z}E_6/\tau_S^3\sigma$:

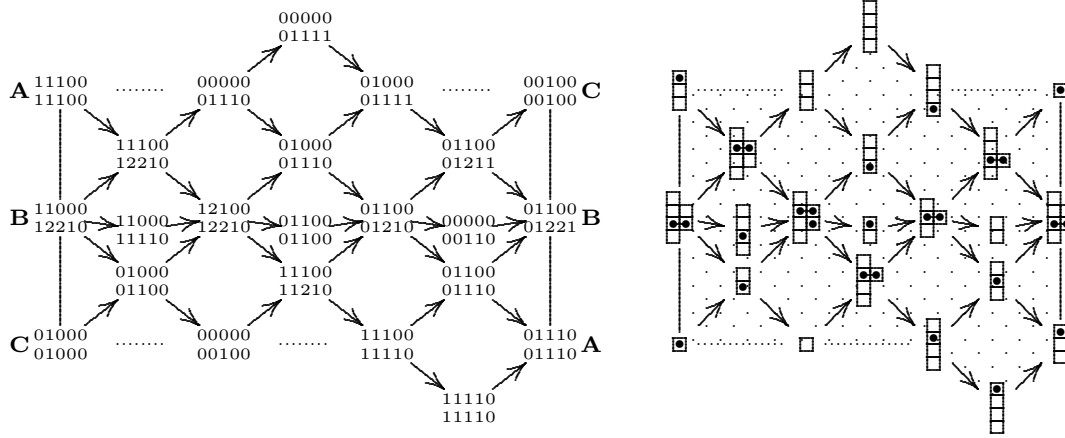

Here are the possible dimension pairs of the indecomposable triples in $\mathcal{S}(4)$.

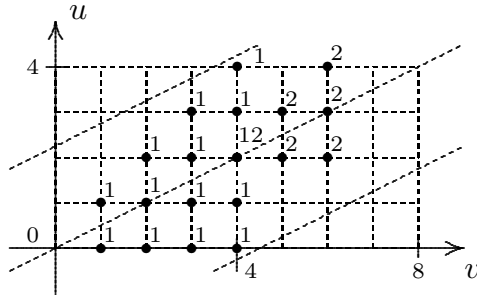

(6.5) The case $n = 5$. For the construction of the Auslander-Reiten quiver for $\mathcal{S}(5)$ we use the methods of Section 1. Here is the result.

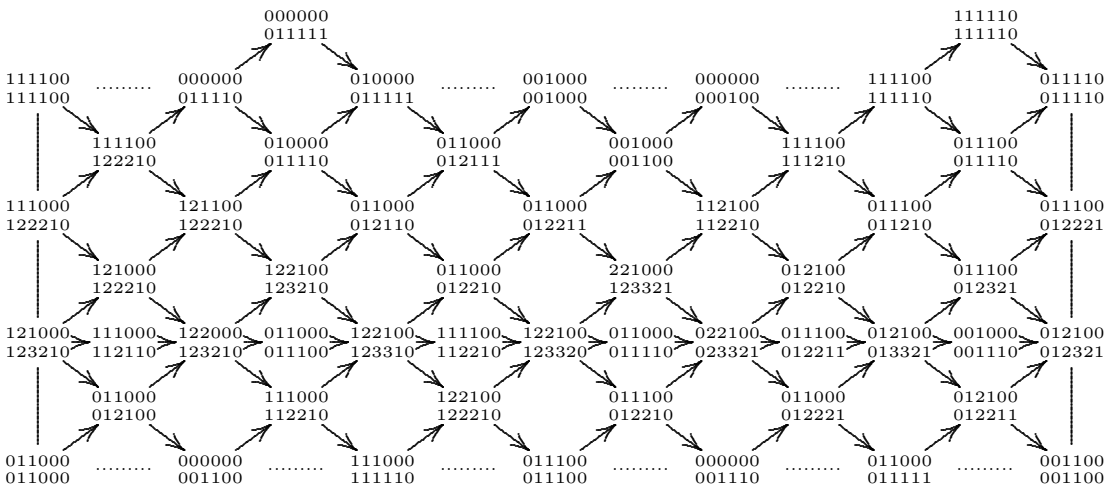

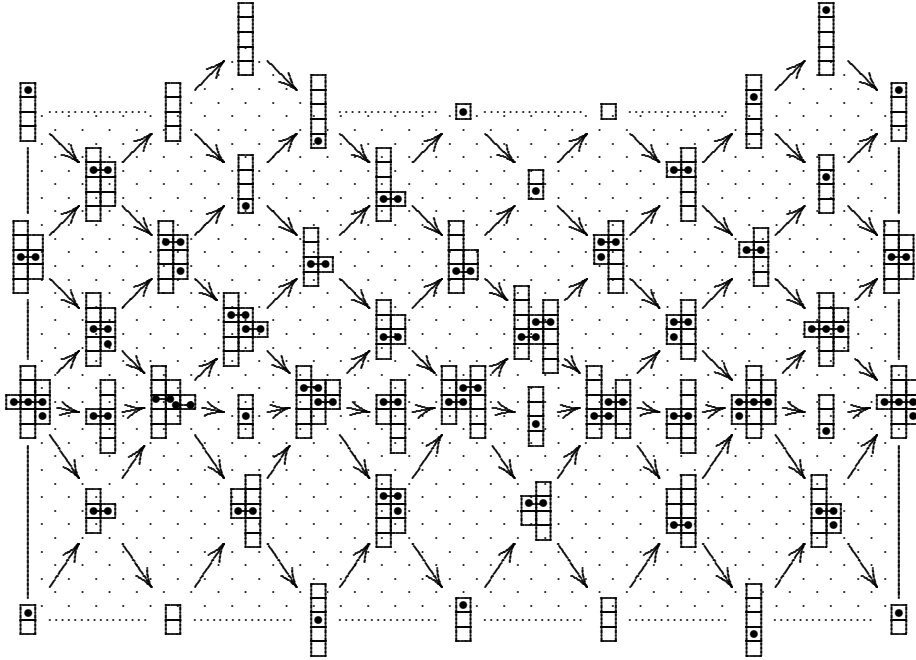

Let us indicate how $\Gamma(5)$ is constructed. We consider the algebra Ψ given by quiver and relations, as indicated.

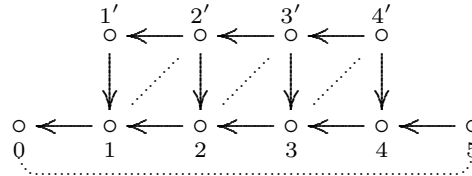

The algebra Ψ has a preprojective component; here is a sketch of the left hand part.

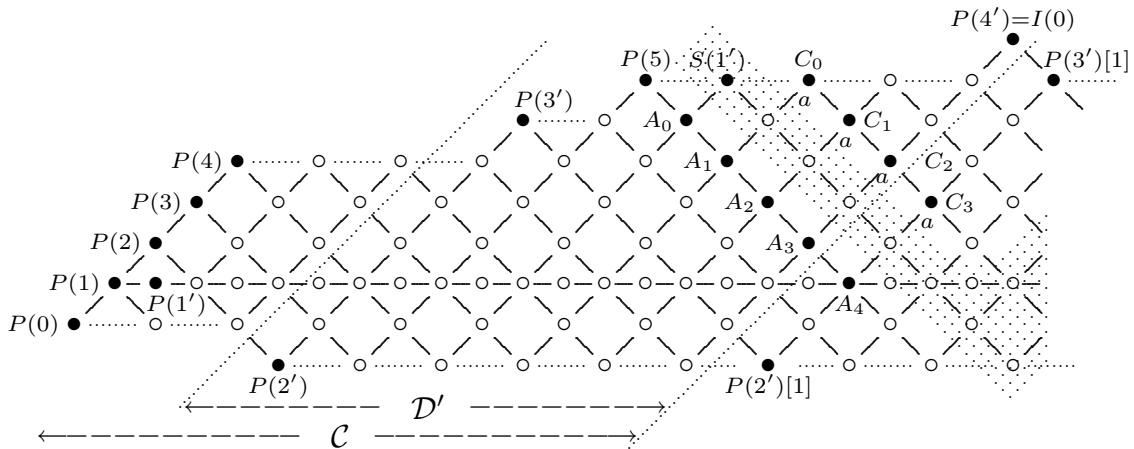

INVARIANT SUBSPACES OF NILPOTENT LINEAR OPERATORS. I.

In \mathcal{D}' , the set of indecomposable Ψ -modules located between the two diagonals in the diagram, each module M for which one of the vertical arrows β_i is not represented by a monomorphism lies on the sectional path starting at the simple module $S(1')$. By deleting this path in \mathcal{D}' we obtain $\mathcal{D} = \mathcal{D}' \cap \mathcal{S}(\tilde{5})$. It follows from the three claims below that the Auslander-Reiten quiver is as pictured.

Claim 1. *The set \mathcal{D} is the fundamental domain in $\mathcal{S}(\tilde{5})$ for the shift.*

Proof: If $M \in \text{ind } \mathcal{S}(\tilde{5})$ satisfies that $M_z = 0 = M_{z'}$ for $z < 0$ and $M_0 \neq 0$ then either β_0 is not an epimorphism and there is a path (even a non-zero map) $M[1] \rightarrow P(5)$ in the category \mathcal{C} , as seen in the proof of Claim 1 in (1.4) or else β_0 is an isomorphism and there is a non-zero map $M \rightarrow I(0) = P(4')$ in the category \mathcal{C} . As a consequence, either $M[1]$ or M occurs in \mathcal{C} . Since all modules in $\mathcal{C} \setminus \mathcal{D}'$ have a translate in \mathcal{D} with respect to the shift, \mathcal{D} is a full set of representatives for the orbits under the shift of the indecomposable representations in $\mathcal{S}(\tilde{5})$. \checkmark

Claim 2. *Each source map in $\text{mod } \Psi$ starting at a Ψ -module in \mathcal{D} is a source map in $\mathcal{S}(\tilde{5})$.*

Proof: Let X be an object in \mathcal{D} and $f : X \rightarrow Y$ a source map in $\text{mod } \Psi$. We show that any non-isomorphism $t : X \rightarrow T$ for $T \in \text{ind } \mathcal{S}(\tilde{5})$ factors over f . Let j be such that $T[j]$ is in \mathcal{D} . If $j > 0$ then $X[j]$ and $T[j]$ are both modules over an algebra Ψ' which is obtained from Ψ by performing one point extensions at radicals of projective modules, as in (1.2). We obtain: $\text{Hom}_{\mathcal{S}}(X, T) = \text{Hom}_{\Psi'}(X[j], T[j]) = 0$. Similarly, if $j \leq 0$ then X and T are both modules over a suitable extension algebra Ψ' of Ψ ; in this case t factors over f since f is a source map in the category $\text{mod } \Psi'$. \checkmark

Claim 3. *Let X be an object in \mathcal{D} . Either the Auslander-Reiten sequence in $\text{mod } \Psi$ starting at X is in $\mathcal{S}(\tilde{5})$, or X is the projective-injective module $P(5)$, or else X is one of the modules A_i , $0 \leq i \leq 3$, in the above diagram, and the relative Auslander-Reiten sequence starting at X has the form $0 \rightarrow A_i \rightarrow A_{i+1} \oplus C_{i-1} \rightarrow C_i \rightarrow 0$ where $C_{-1} = 0$.*

Proof: See Lemma (1.3.1) for the source map of $P(5)$; the four maps labelled “a” in the diagram are left $\mathcal{S}(\tilde{5})$ -approximations, so each Auslander-Reiten sequence starting at one of the A_i is as claimed. \checkmark

We conclude this section with the picture of the dimension pairs, and the corresponding Krull-Remak-Schmidt multiplicities of the total space, of the inde-

composable triples in $\mathcal{S}(5)$.

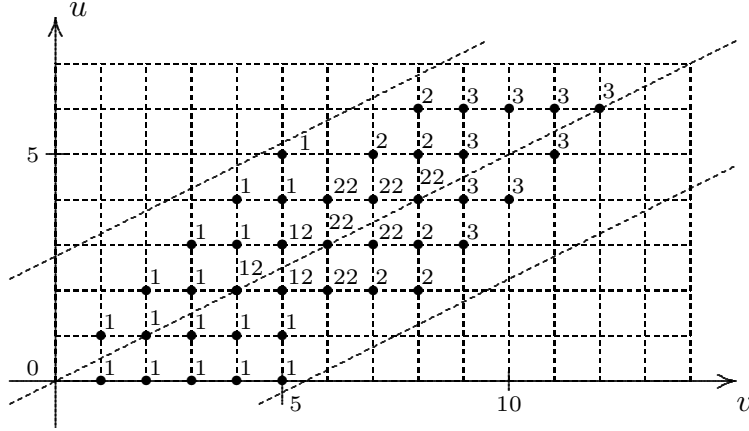

(6.6) A formula for the number of indecomposables. The number $s(n)$ of indecomposable objects in $\mathcal{S}(n)$ is predicted by the formula $s(n) = 2 + 2(n-1)\frac{6}{6-n}$. If the stable part of $\Gamma(n)$ is of type $\mathbb{Z}\Delta/\varphi$, then the Auslander-Reiten quiver of $\mathcal{S}(\tilde{n})$ has stable type $\mathbb{Z}\Delta$ and we read off from the sequence of boundary modules that within each interval of six $\tau_{\mathcal{S}}$ -translations in $\mathbb{Z}\Delta$ there will occur $6-n$ translates of each boundary module. This accounts for the factor $\frac{6}{6-n}$ in the formula. In fact for $n < 6$ and for every indecomposable non-projective module M in the covering category $\mathcal{S}(\tilde{n})$, the quotient q_n of the $\tau_{\mathcal{S}}$ -period, up to the shift, and the number of $\tau_{\mathcal{S}}$ -orbits containing one of the $M[i]$ is equal to $\frac{6}{6-n}$ (and independent of M). By checking each case, we see that the Dynkin diagram Δ has $2(n-1)$ points — the other factor in the formula. The product of the two factors is the number $2(n-1) \cdot \frac{6}{6-n}$ of indecomposables in the stable part of the Auslander-Reiten quiver for $\mathcal{S}(n)$. Two more indecomposables are not represented in the stable part, namely the projective-injective ones.

In the table below we list some numerical data about the Auslander-Reiten quivers of the categories $\mathcal{S}(n)$. By σ and ρ we denote automorphisms of the underlying Dynkin diagram of order 2 and 3, respectively.

n	1	2	3	4	5	6
$2(n-1)$	0	2	4	6	8	10
stable part of $\Gamma(\tilde{n})$	—	$\mathbb{Z}A_2$	$\mathbb{Z}D_4$	$\mathbb{Z}E_6$	$\mathbb{Z}E_8$	$\textcircled{E_8}$
$\frac{6}{6-n}$	$\frac{6}{5}$	$\frac{3}{2}$	2	3	6	∞
q_n	—	$\frac{3}{2}$	2	3	6	—
stable part of $\Gamma(n)$	—	$\mathbb{Z}A_2/\tau^{\frac{3}{2}}\sigma$	$\mathbb{Z}D_4/\tau^2\rho$	$\mathbb{Z}E_6/\tau^3\sigma$	$\mathbb{Z}E_8/\tau^6$	$\textcircled{E_8}$
$2 + 2(n-1)\frac{6}{6-n}$	2	5	10	20	50	∞
# indec. in $\Gamma(n)$	2	5	10	20	50	∞

We would like to point out that the formula $s(n) = 2 + 2(n-1)\frac{6}{6-n}$ predicts the number of indecomposables correctly for all values $0 \leq n \leq 6$. In the case where $n = 6$ (and where $s(6)$ is predicted correctly as ∞), even the first factor $2(n-1)$ in the formula can be interpreted as the number of points of the underlying diagram. In fact, we have seen that the category $\mathcal{S}(6)$ arises as a coextension of a tame concealed algebra of type \tilde{E}_8 and in this sense is associated with $8 + 1 + 1 = 10 = 2(6-1)$ points.

7. Three Remarks about Wild Submodule Categories.

In the cases where $n \geq 7$, the categories $\mathcal{S}(\tilde{n})$ and $\mathcal{S}(n)$ have wild representation type. In fact, it is shown in [10] that for any commutative local uniserial ring Λ of Loewy length 7 the category $\mathcal{S}(\Lambda)$ is controlled k -wild where k is the radical factor field of Λ .

In this section we use the boundary modules and our knowledge about the periodicity of the translation to describe the shape of the connected components of the Auslander-Reiten quiver for $\mathcal{S}(\tilde{n})$ and $\mathcal{S}(n)$ where $n \geq 7$. Moreover, we construct an indecomposable object in $\mathcal{S}(\tilde{n})^{\text{lfd}}$ which does not have finite support. Thus for $n \geq 7$ the category $\mathcal{S}(\tilde{n})$ is not locally support finite.

We have seen that for $\mathcal{S}(6)$, the region in $\mathbb{Z} \times \mathbb{Z}$ containing the possible dimension pairs of indecomposable objects is contained in a stripe. We show in (7.3) that this is no longer the case in $\mathcal{S}(n)$ when $n \geq 7$.

(7.1) The connected components of the Auslander-Reiten quiver.

(7.1.1) Proposition. *Let $n \geq 7$.*

- (a) *Each component of the Auslander-Reiten quiver $\Gamma(\tilde{n})$ for $\mathcal{S}(\tilde{n})$ has stable part of type $\mathbb{Z}A_\infty$. All components in $\Gamma(\tilde{n})$ are stable with the exception of $n-6$ components which contain boundary modules.*
- (b) *The stable part of each component of the Auslander-Reiten quiver $\Gamma(n)$ for $\mathcal{S}(n)$ is a tube of rank 1, 2, 3, or 6. All components are stable with the exception of one tube of rank 6 which contains the boundary modules.*

Proof: (b) Let \mathcal{C} be a connected component of $\Gamma(n)$. The length function on \mathcal{C} gives rise to a subadditive function on the stable part of \mathcal{C} which is an unbounded function since \mathcal{C} is not a finite component. Under the Auslander-Reiten translation, every indecomposable module in $\Gamma(n)$ has a period which is a divisor of 6 ([11], Corollary 6.5), and hence \mathcal{C} contains periodic modules. Thus [7], Theorem 2, implies that the diagram of the stable part of \mathcal{C} is $\mathbb{Z}A_\infty/G$ where G is an admissible group of automorphisms of $\mathbb{Z}A_\infty$. More precisely, the stable part of \mathcal{C} is a tube of rank a divisor of 6. Since the boundary modules have $\tau_{\mathcal{S}}$ -period 6 whenever $n \geq 3$, we obtain that both projective-injective indecomposables occur in one tube of rank 6.

(a) A connected component $\tilde{\mathcal{C}}$ of $\Gamma(\tilde{n})$ cannot contain any periodic modules if $n \geq 7$, since for every object M in such a component there is an isomorphism

$\tau_S^6 M \cong M[n-6]$. Since the component \mathcal{C} of the Auslander-Reiten quiver for $\mathcal{S}(n)$ corresponding to $\tilde{\mathcal{C}}$ under the covering functor has stable part a tube of rank a divisor of 6, the category $\tilde{\mathcal{C}}$ must have stable part $\mathbb{Z}A_\infty$. In $\mathcal{S}(\tilde{n})$, there are $n-6$ τ_S -orbits of boundary modules, they give rise to the $n-6$ non-stable components in $\Gamma(\tilde{n})$. ✓

(7.2) Objects in $\mathcal{S}(\tilde{n})$ with large support.

(7.2.1) Proposition. *For $n \geq 7$, the category $\mathcal{S}(\tilde{n})$ is not locally support finite.*

Proof: We construct a finite dimensional indecomposable representation N and a locally finite dimensional indecomposable representation M such that there is a short exact sequence

$$0 \longrightarrow M[1] \longrightarrow M \longrightarrow N \longrightarrow 0.$$

We present our construction of M and N for the case $n = 7$ and the component of $\Gamma(\tilde{7})$ containing the boundary modules (but this construction works for any $n \geq 7$ and any other component, too).

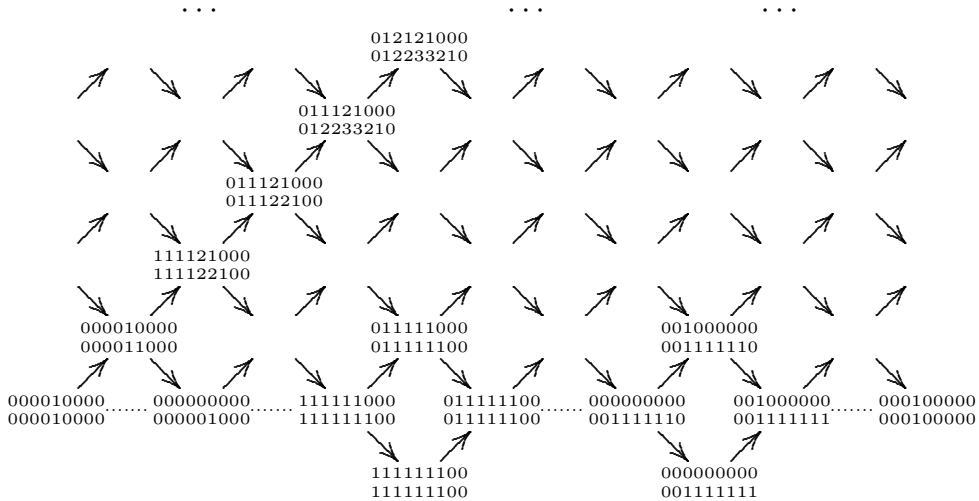

We start with the module N with dimension vector $\begin{smallmatrix} 012121000 \\ 012233210 \end{smallmatrix}$ and with a sectional path $K(4) \rightarrow N$ formed by irreducible maps. Note that $\tau^6 N$ is just the module $N[1]$, and the Auslander-Reiten component exhibits a non-split extension $0 \rightarrow N[1] \rightarrow N^2[1] \rightarrow N \rightarrow 0$. Here we sketch a part of the component:

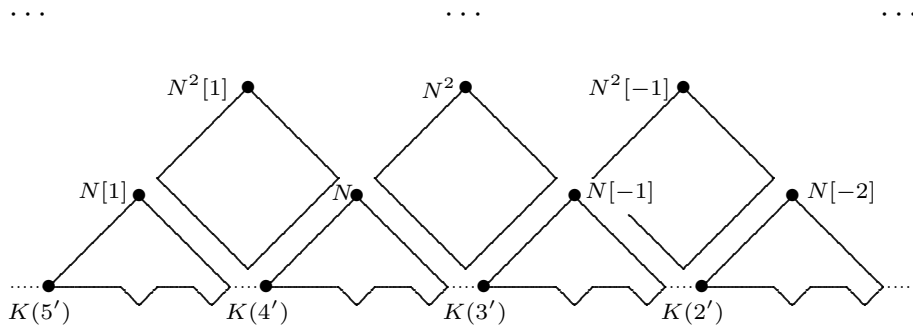

INVARIANT SUBSPACES OF NILPOTENT LINEAR OPERATORS. I.

Similarly we obtain for each $m \in \mathbb{N}$ an indecomposable module $N^{m+1}[m]$ and a non-split extension

$$0 \longrightarrow N[m] \longrightarrow N^{m+1}[m] \xrightarrow{\phi_m} N^m[m-1] \longrightarrow 0$$

and define $(M, \psi_m : M \rightarrow N^m[m-1])$ to be the limit of the inverse system $(\phi_i)_{i \in \mathbb{N}}$. The module M is locally finite dimensional with dimension vector $\begin{smallmatrix} 0 & 1 & 3 & 4 & 6 \\ 7 & 7 & 7 & 7 & \dots \end{smallmatrix}$, and each map ψ_m is the canonical map modulo $M[m]$. Moreover, the mapping property of the inverse limit yields a map $M[1] \rightarrow M$ which has cokernel N .

We claim that M is indecomposable in $\mathcal{S}(\tilde{7})^{\text{lfid}}$. Let $M = U \oplus V$ be a direct sum decomposition in $\mathcal{S}(\tilde{7})^{\text{lfid}}$. We assume that U and V are both non-zero and fix $\ell \in \mathbb{N}$ such that $U_\ell \neq 0$ and $V_\ell \neq 0$. Since $\psi_\ell(M)_\ell = M_\ell$ we obtain a proper decomposition $\psi_\ell(M) = \psi_\ell(U) \oplus \psi_\ell(V)$, in contradiction to the indecomposability of $\psi_\ell(M) = N^\ell[\ell-1]$. ✓

(7.3) Dimension pairs in $\mathcal{S}(n)$ for $n \geq 7$.

(7.3.1) Proposition. *For $n \geq 7$, the dimension pairs of indecomposable triples in the category $\mathcal{S}(n)$ are not contained in any stripe.*

Proof: We specify two families of indecomposable triples which have dimension pairs that lie on two lines which have different slope. More precisely, for each $f > 0$ we construct two modules \bar{M}^+ and \bar{M}^- in $\mathcal{S}(7)$ such that $\mathbf{dim} \bar{M}^+ = f \cdot (13, 6)$ and $\mathbf{dim} \bar{M}^- = f \cdot (13, 7)$, so $\mathbf{dim} \bar{M}^+$ and $\mathbf{dim} \bar{M}^-$ have vertical distance f . This shows that there is no stripe which contains all dimension pairs.

Given $f > 0$, let M be an f -fold selfextension of a module on the mouth of one of the homogeneous tubes in \mathcal{U} in $\mathcal{S}(\tilde{6})$, say corresponding to parameter $c \in k \setminus \{0, 1\}$, so M has dimension vector $\mathbf{dim} M = f \cdot \mathbf{h}^\infty$. Let M^+ be the representation in $\mathcal{S}(\tilde{7})$ obtained from M by replacing $M_7 = 0$ by $M_7^+ = M_6$ and by taking for $M_{\alpha_7}^+$ the identity map on M_6 . Similarly, let M^- be obtained from M by replacing $M_0 = 0 = M_{0'}$ by $M_0^- = M_1 = M_{1'} = M_{0'}$ and by taking as maps $M_{\beta_0}^- = M_{\alpha_1}^- = M_{\alpha_1'}^- = 1_{M_1}$. Then M^+ and M^- have dimension vectors

$$\mathbf{dim} M^+ = f \cdot \begin{smallmatrix} 0 & 1 & 2 & 2 & 1 \\ 0 & 1 & 2 & 3 & 3 & 2 & 1 & 1 \end{smallmatrix} \quad \text{and} \quad \mathbf{dim} M^- = f \cdot \begin{smallmatrix} 1 & 1 & 2 & 2 & 1 \\ 1 & 1 & 2 & 3 & 3 & 2 & 1 & 0 \end{smallmatrix},$$

respectively. Both modules are indecomposable since a decomposition would give rise to a decomposition of M .

For \bar{M}^+ and \bar{M}^- take the image of M^+ and M^- under the covering functor, this yields indecomposable objects by Proposition (2.1.1). In case $f = 2$, they can be pictured as follows (for the notation see Section 2.3):

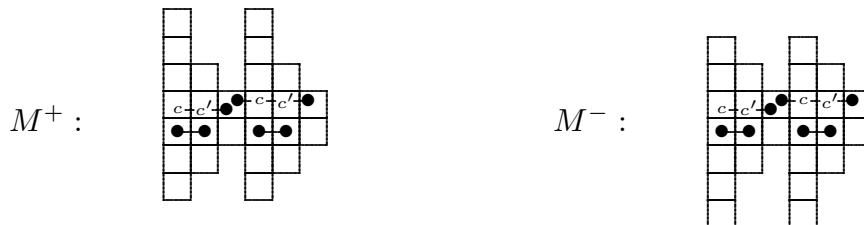

The dimension pairs of \bar{M}^+ and \bar{M}^- are as stated above. ✓

Appendix. Operators which are not nilpotent.

We conclude with a remark on invariant subspaces of operators which are not necessarily nilpotent. In this section we deal with the more general case where the linear operator does not act nilpotently on the vector space. We assume that the minimal polynomial of the operator is a product of linear factors and demonstrate that the classification of the invariant subspaces can be reduced to the nilpotent case.

Let (V, U, T) be a triple consisting of a finite dimensional k -vector space V , a subspace U of V and a linear map $T: V \rightarrow V$ which maps U into U .

Suppose that the minimal polynomial $\min_T(x)$ for T factors as

$$\min_T(x) = p_1^{n_1}(x) \cdots p_s^{n_s}(x)$$

where the p_i are pairwise distinct monic irreducible polynomials. Then the vector space V has primary decomposition

$$V = V_{p_1} \oplus \cdots \oplus V_{p_s} \quad \text{where the} \quad V_{p_i} = \{v \in V \mid p_i^{n_i}(T)(v) = 0\}$$

are invariant subspaces of V with minimal polynomials $\min_{T|_{V_{p_i}}}(x) = p_i^{n_i}(x)$.

Since U is an invariant subspace of V , the minimal polynomial for $T|_U$ is a divisor of the minimal polynomial for T and hence U has a corresponding primary decomposition $U = U_{p_1} \oplus \cdots \oplus U_{p_s}$. Thus,

$$(V, U, T) = (V_{p_1}, U_{p_1}, T|_{V_{p_1}}) \oplus \cdots \oplus (V_{p_s}, U_{p_s}, T|_{V_{p_s}})$$

is a decomposition where each operator $T|_{V_{p_i}}$ has a minimal polynomial which is a power of an irreducible polynomial.

If $p_i(x)$ is a linear polynomial, then the operator $S_i = p_i(T)$ is a linear operator which acts nilpotently on V_{p_i} and which fixes the subspace U_{p_i} .

In conclusion, we have reduced the decomposition problem for the triple (V, U, T) where T is an arbitrary k -linear operator whose minimal polynomial is a product of linear factors, to the corresponding problem for the triples (V_{p_i}, U_{p_i}, S_i) where S_i is a nilpotent linear operator.

References

[1] *M. Auslander, I. Reiten, S. O. Smalø*, Representation Theory of Artin Algebras, Cambridge University Press (1995).
 [2] *G. Birkhoff*, Subgroups of abelian groups, Proc. Lond. Math. Soc., II. Ser. **38** (1934), 385–401.

INVARIANT SUBSPACES OF NILPOTENT LINEAR OPERATORS. I.

- [3] *K. Bongartz and P. Gabriel*, Covering spaces in representation theory, *Inventiones Math.* **65** (1982), 331–378.
- [4] *N. Bourbaki*, *Groupes et algèbres de Lie*, Chapitres 4,5 et 6, Masson, Paris, 1981.
- [5] *P. Dowbor, H. Lenzing, A. Skowronski*, Galois coverings by algebras of locally support-finite categories, in: *Representation theory I*, Proc. Conf. Ottawa (1984), 91–93.
- [6] *P. Gabriel*, The universal cover of a representation-finite algebra. in: *Representations of Algebras*, Springer LNM **903** (1981), 68–105.
- [7] *D. Happel, U. Preiser, and C. M. Ringel*, Vinberg’s characterization of Dynkin diagrams using subadditive functions with application to *DTr*-periodic modules. in: *Representation Theory II*, Proc. Conf. Ottawa 1979, Springer LNM **832** (1980), 280–294.
- [8] *F. Richman and E. A. Walker*, Subgroups of p^5 -bounded groups, in: *Abelian groups and modules*, Trends Math., Birkhäuser, Basel, (1999), 55–73.
- [9] *C. M. Ringel*, *Tame Algebras and Integral Quadratic Forms*, Springer LNM **1099** (1984).
- [10] *C. M. Ringel and M. Schmidmeier*, Submodule categories of wild representation type, *J. Pure and Applied Alg.* **205** (2006), 412-422.
- [11] *C. M. Ringel and M. Schmidmeier*, The Auslander-Reiten translation in submodule categories, to appear in: *Transactions of the AMS*.
- [12] *C. M. Ringel and M. Schmidmeier*, Invariant subspaces of nilpotent linear operators. II. In preparation.
- [13] *M. Schmidmeier*, Bounded submodules of modules, *J. Pure and Applied Alg.* **203** (2005), 45–82.
- [14] *D. Simson*, Chain categories of modules and subprojective representations of posets over uniserial algebras, *Rocky Mountain J. Math.* **32** (2002), 1627–1650.

Claus Michael Ringel, Fakultät für Mathematik, Universität Bielefeld,
POBox 100 131, D-33 501 Bielefeld
`ringel@math.uni-bielefeld.de`

Markus Schmidmeier, Department of Mathematical Sciences, Florida Atlantic University,
Boca Raton, Florida 33431-0991
`markus@math.fau.edu`